



# LD8001

## USER'S MANUAL

TRACE NITROGEN IN ARGON, HELIUM AND CRUDE ARGON GAS ANALYZER





***LD8001***

Trace Nitrogen analyzer

**USER'S MANUAL**  
V1.3



## Table of Contents

Table of Contents .....	4
Table of Figures .....	5
1. Forewarning .....	6
2. Warranty and service policies .....	7
3. Declaration of conformity .....	10
4. Specifications .....	12
5. Installation.....	13
5.1. Storage and handling instructions .....	13
5.2. Analyzer application .....	14
5.3. Start-up.....	14
5.4. Shut-off .....	15
5.5. Typical installation.....	16
6. Hardware description .....	20
6.1. Detectors .....	20
6.2. Motherboard.....	21
6.3. Sample gas proportional valve.....	22
6.4. Display with Touch Screen (7" 800x480).....	22
6.5. Serial port.....	22
6.6. Relays.....	22
6.7. 4-20mA module .....	23
7. Operation.....	24
7.1. User interface .....	24
7.2. Software procedures.....	30
8. Drawings & Schematics.....	39
8.1. Part Identification.....	40
8.2. Back Panel Identification.....	41
8.3. Back Panel pins Identification .....	42
8.4. Electrical schematic (block diagram).....	43
8.5. Electrical schematic (internal view).....	44
8.6. Enclosure Dimensions & Panel Cutout.....	45
8.7. Back Facia Panel.....	46
9. Maintenance and troubleshooting .....	47
9.1. Spare part list .....	47
9.2. Tools .....	47
9.3. Maintenance procedures .....	48
9.4. Troubleshooting.....	52

## Table of Figures

Figure 1: Typical Installation with LDGSS	17
Figure 2: Typical Installation with integrated stream selector .....	18
Figure 3: Typical Installation with zero gas free.....	19
Figure 4: Type of Detectors .....	20
Figure 5: LD8001 printed circuit board (PCB) .....	21
Figure 6: Solenoid proportional valve.....	22
Figure 7: Analysis menu .....	24
Figure 8: Settings menu .....	26
Figure 9: Calibration menu .....	27
Figure 10: Diagnostic menu .....	28
Figure 11: More menu.....	29
Figure 12: HCD box.....	49
Figure 13: LD8001 fan.....	49

---

## 1. Forewarning

Any user that wants to use the LD8001 Trace Nitrogen analyzer must read this manual. It contains valuable information to successfully operate this instrument. LDetek assumes that all operators have taken the time to read this information before installing, operating, and troubleshooting this analyzer.

If any error is suspected by the reader, please contact LDetek. LDetek reserves the right to make any changes to subsequent editions of this document without prior notice to holders of this edition.

In no event shall LDetek be liable for any damages arising out of or related to this document or the information contained in it.

We want to thank you for choosing LDetek as your gas analyzer supplier.

---

## 2. Warranty and service policies

Goods and part(s) (excluding consumables) manufactured by the seller are warranted to be free from defects in workmanship and material under normal use and service for **twelve (12) months** after installation and start-up and not exceeding **eighteen (18) months** from shipment date. Consumable, chemical traps, O-rings, etc., are warranted to be free from defects in workmanship and material under normal use and service for a period of **ninety (90) days** from the date of shipment by the seller. Goods, part(s) proven by the seller to be defective in workmanship and/or material shall be replaced or repaired, free of charge, F.O.B. Seller's factory provided that the goods, part(s) are returned to Seller's designated factory, transportation charges prepaid, within the twelve (12) months after installation and start-up and not exceeding 18 months from shipment date. In the case of consumables, within the ninety (90) days period of warranty, a defect in goods, part(s) and consumable of the commercial unit shall not operate to condemn such commercial unit when such goods, part(s) and consumable are capable of being renewed, repaired or replaced.

The Seller shall not be liable to the Buyer, or any other person, for the loss or damage directly or indirectly, arising from the use of the equipment of goods, from breach of any warranty, or any other cause.

**ALL OTHER WARRANTIES, EXPRESSED OR IMPLIED ARE HEREBY EXCLUDED.**

IN CONSIDERATION OF THE HEREIN-STATED PURCHASE PRICE OF THE GOODS, THE SELLER GRANTS ONLY THE ABOVE-STATED EXPRESS WARRANTY. NO OTHER WARRANTIES ARE GRANTED INCLUDING, BUT NOT LIMITED TO, EXPRESS AND IMPLIED WARRANTIES OF MERCHANTABILITY AND FITNESS FOR A PARTICULAR PURPOSE.

THIS WARRANTY IS THE ONLY WARRANTY MADE BY LDETEK INC. FOR THE GOODS DELIVERED HEREUNDER, AND NO EMPLOYEE, REPRESENTATIVE OR OTHER PERSON OR ENTITY IS AUTHORIZED TO ASSUME FOR LDETEK INC ANY OBLIGATION OR LIABILITY BEYOND OR AT VARIANCE WITH THIS WARRANTY IN CONNECTION WITH THE SALE OF LDETEK PRODUCTS.

**Limitations of Remedy.** SELLER SHALL NOT BE LIABLE FOR DAMAGES CAUSED BY DELAY IN PERFORMANCE. THE SOLE AND EXCLUSIVE REMEDY FOR BREACH OF WARRANTY SHALL BE LIMITED TO REPAIR OR REPLACEMENT UNDER THE STANDARD WARRANTY CLAUSE. IN NO CASE, REGARDLESS OF THE FORM OF THE CAUSE OF ACTION, SHALL THE SELLER'S LIABILITY EXCEEDS THE PRICE TO THE BUYER OF THE SPECIFIC GOODS

MANUFACTURED BY SELLER GIVING RISE TO THE CAUSE OF ACTION. BUYER AGREES THAT IN NO EVENT SHALL SELLER'S LIABILITY EXTEND TO INCLUDE INCIDENTAL OR CONSEQUENTIAL DAMAGES. CONSEQUENTIAL

---

DAMAGES SHALL INCLUDE BUT ARE NOT LIMITED TO, LOSS OF ANTICIPATED PROFITS, LOSS OF USE, LOSS OF REVENUE, COST OF CAPITAL AND DAMAGE OR LOSS OF OTHER PROPERTY OR EQUIPMENT. IN NO EVENT SHALL THE SELLER BE LIABLE FOR PROPERTY DAMAGE AND/OR THIRD-PARTY CLAIMS COVERED BY UMBRELLA INSURANCE AND/OR INDEMNITY COVERAGE PROVIDED TO THE BUYER, ITS ASSIGNS, AND EACH SUCCESSOR INTEREST TO THE GOODS PROVIDED HEREUNDER.

**Major force.** The seller is not liable for failure to perform due to labour strikes or acts beyond the seller's direct control.

### **SERVICE POLICY**

1. If a product should fail during the warranty period, it will be repaired free of charge. For out-of-warranty repairs, the customer will be invoiced for repair charges at current standard labour and materials rates.
2. Customers who return products for repairs, within the warranty period, and the product is found to be free of defect, may be liable for the minimum current repair charge.
3. For parts replacement, the original part must be returned with the serial and model numbers of the analyzer. **NO PART WILL BE SHIPPED IF THE ORIGINAL IS NOT SENT BACK TO LDETEK INC.**

### **RETURNING A PRODUCT FOR REPAIR**

Upon determining that repair services are required, the customer must:

- Obtain an RMA (Return Material Authorization) number.
- Supply a purchase order number or other acceptable information.
- Include a list of problems encountered along with the name, address, telephone, and RMA number.
- Ship the analyzer in its original crating or equivalent. Failure to properly package the analyzer will automatically void the warranty.
- Every gas connection must be capped with appropriate metal caps. Failure to do so will automatically void the warranty.
- Write the RMA number on the outside of the box.
- Use an LDetek-approved carrier. Also, the delivery must be sent to LDetek facilities. LDetek will not accept airport-to-airport delivery.
- LDetek will not cover the transportation fees.

Other conditions and limitations may apply to international shipments.

## **PROPRIETARY RIGHTS**

Buyer agrees that any LDetek's software, firmware and hardware products ordered or included in the goods ordered are proprietary of LDetek. No change, modification, defacement, alteration, reverse engineering, neither software de-compilations nor reproductions of such software or hardware products, or disclosures of programming content to other parties are authorized without the express written consent of LDetek.

To maintain LDetek's trade secret and other proprietary protection of such software and firmware, such items are not sold hereunder but are licensed to the buyer.

LDetek Inc. reserves the right to interrupt all business relationships and warranty or service if there is any tentative from any customers to reverse engineering any of LDetek products or to tamper with any sealed module.

Trademarks and product identification as LD8001 are the property of LDetek Inc. and shall be used only in connection with LDetek's products. No third party could remove or deface any model number or marks.

### 3. Declaration of conformity

## EU Declaration of Conformity



1. **Product model:** LD8001 online analyser series

2. **Name and address of the manufacturer:**

LDetek Inc.  
 990 Monfette E.  
 Thetford Mines, QC G6G 7K6  
 +1 (418) 755-1319  
 Email: info@ldetek.com

This product is in conformity with the following EU Directives ,Standard(s) or Normative Document(s):

3. **Standards:**

Test name Standard	Limit Test level	EUT	Results
Measurement of conducted emissions on the supply line CISPR 32: 2015 A1: 2019	Class A	E41428	Pass
Measurement of conducted emissions on the supply line FCC Part 15, Subpart B: 2021	Class A	E41428	Pass
Measurement of radiated emissions (30 MHz – 6 GHz) CISPR 32: 2015 A1: 2019	Class A	E41428	Pass
Measurement of radiated emissions (30 MHz – 7.5 GHz) FCC Part 15, Subpart B: 2021	Class A	E41428	Pass
Radiated electromagnetic field immunity – radio frequencies IEC 61000-4-3: 2020	Scan: 10 V/m (80 MHz – 1 GHz) 3 V/m (1.4 GHz – 6 GHz)	E41428	Pass
Conducted immunity IEC 61000-4-6: 2013	10 V power line	E41428	See Sec. 4
Electrostatic discharge immunity IEC 61000-4-2: 2008	±4 kV contact ±8 kV air	E41428	Pass

Test name Standard	Limit Test level	EUT	Results
Electrical fast transient immunity IEC 61000-4-4: 2012	±2 kV power line	E41428	Pass
Surge immunity IEC 61000-4-5: 2014 A1: 2017	±1 kV L - L ±2 kV L - Ground	E41428	Pass
Magnetic field immunity IEC 61000-4-8: 2009	30 A/m, 50 Hz	E41428	Pass
Voltage dips, short interruptions and voltage variations immunity IEC 61000-4-11: 2020	0 % - 1 cycle 40 % - 10 cycle 70 % - 25 cycles 0 % - 250 cycles	E41428	Pass

4. **On behalf of the above-named company, I declare that under our sole responsibility, on the date that the equipment accompanied by this declaration is placed on the market, it conforms with all technical and regulatory requirements of the above listed EU Directives.**



Dany Gagné / CTO  
 Thetford Mines, QC  
 Date: 03/23

990, rue Monfette Est, Thetford Mines G6G 7K6  
 Tél. 418 755-1319, Tél. 418 755 1329

## UK Declaration of Conformity



1. **Product model:** LD8001
2. **Name and Address of the manufacture:**

LDetek Inc.  
990 Monfette E.  
Thetford Mines, QC G7K6  
+1 (418) 755-1319  
Email: [info@ldetek.com](mailto:info@ldetek.com)

UK  
CA

3. **This declaration is issued under the sole responsibility of the manufacturer.**
4. **4. Object of the declaration:**

Product: LD8001

**The object of the declaration described above is in conformity with the relevant UK Statutory Instruments (and their amendments):**

Electrical Equipment (Safety) Regulations 2016: S. I. 2016:1101

Electromagnetic Compatibility Regulations 2016: S.I. 2016:1091

The Restriction of the use of certain hazardous substances in electrical and electronic equipment regulations, 2012: S.I. 2012:3032

Pressure Equipment (Safety) Regulations 2016: S.I. 2016:1105.

RoSH Directive 2011/65/EU

5. **References to the relevant harmonised standards used or references to the other technical specifications in relation to which conformity is declared:**

Reference & date	Title
IEC 61000-4-8:2009	Magnetic field immunity
IEC 61000-4-3:2020	Radiated electromagnetic field immunity – radio frequencies
IEC 61000-4-6:2013	Conducted immunity
IEC 61000-4-2:2008	Electrostatic discharge immunity
IEC 61000-4-4:2012	Electrical fast transient immunity
IEC 61000-4-11:2020	Voltage dips short interruptions and voltage variations immunity
IEC 61000-4-5:2014A1:2017	Surge immunity

On behalf of the above-named company, I declare that under our sole responsibility, on the date that the equipment accompanied by this declaration is placed on the market, it conforms with all technical and regulatory of the above listed UK Directives and UL standards.

Signed for and behalf of:



\_\_\_\_\_  
Dany Gagné / CTO  
Thetford Mines, QC, Canada  
Date: 03/23

## 4. Specifications

<b>Detector type:</b>	Plasma Emission Detector (PED)
<b>Range:</b>	0-1, 0-10 and 0-100 ppm as standard. Other range possible on request
<b>Accuracy:</b>	Better than $\pm 1\%$ full scale
<b>Standard features:</b>	<ul style="list-style-type: none"> <li>• Manual or auto-ranging (user selectable)</li> <li>• Microprocessor controlled</li> <li>• 7" 800x480 Display with Touch Screen</li> <li>• Self-diagnosis system with auto-resolve alarm</li> <li>• Alarm Historic</li> <li>• Safe calibration procedure to avoid any bad calibration</li> <li>• Configurable digital outputs (dry contacts) for remote monitoring               <ul style="list-style-type: none"> <li>➤ System status, alarms, ranges</li> </ul> </li> </ul>
<b>Options:</b>	<ul style="list-style-type: none"> <li>• 4-20 mA isolated output</li> <li>• Serial Communication: Modbus RS-232, RS-422, RS-485, TCP/IP, Profibus</li> <li>• Internal sampling system for zero, span and samples</li> <li>• Zero calibration gas free system</li> </ul>
<b>Gas connections:</b>	Sample: 1/8" Stainless Steel double compression compatible tube fitting Vent: 1/8" Stainless Steel double compression compatible tube fitting
<b>Calibration gas:</b>	Zero: LDP1000 purified gas (Getter) Span: 75% to 90% of the working range of N <sub>2</sub> in Argon or Helium
<b>Sample flow requirements:</b>	75 to 200 sccm
<b>Operating sample pressure range:</b>	3 (20 kPag) to 30 psig (138 kPag) (Low-pressure option available)
<b>Outlet pressure:</b>	Atmospheric
<b>Operating temperature:</b>	10 °C to 45 °C (but stable environment)
<b>Supply:</b>	115 VAC, 50 – 60 Hz or 220 VAC, 50 – 60 Hz
<b>Power consumption:</b>	Maximum 40 watts
<b>Response time:</b>	T90 <10 seconds
<b>Drift:</b>	$\pm 1\%$ over 24 hours
<b>Ingress protection:</b>	IP20 in accordance with IEC 60529
<b>Enclosure type:</b>	3U
<b>Dimensions:</b>	133mm (5-1/4") high X 446mm (17-1/2") wide X 375mm (14-3/4") deep
<b>Weight:</b>	29 lbs (13 kg)

---

## 5. Installation

### 5.1. Storage and handling instructions

#### 5.1.1. Analyzer storage instructions

In order for this product to be functional upon installation it should be stored in accordance with the guidelines below:

- The product must be housed in a sheltered area, out of direct sunlight and rain.
- The product should be stored to minimize the possibility of sitting in ground water.
- The temperature within the storage environment should be maintained between +10 and +30 °C (50 and +85 °F).
- The humidity within the storage environment must be 10 to 95 %RH
- The storage environment must not expose the analyzer to any corrosive elements.
- All electrical and process connections should remain disconnected and capped.
- All protective coatings should remain in place until installation.
- Any documentation supplied with the product should be removed from the packing crate and stored elsewhere to protect its integrity.
- Storing the product for longer than 6 months could affect the time required for start-up.

#### 5.1.2. Detector cautions

The LD8001 utilizes a Plasma Emission Detector (PED) that have been well-established in the industry for many years.

#### **PED**

The PED operates on the principle of spectroscopic emission. A pure quartz cell is placed in an electromagnetic field generated by a specific high-intensity generator. This electromagnetic field creates plasma, which emits light at different wavelengths. By using appropriate optical filters, the detector can detect the desired impurities. One of the key benefits of the PED is its ability to offer a selective mode based on the spectral line used to measure specific impurities, providing both selectivity and sensitivity.

To prevent the quartz cell from cracking, it is important to maintain **atmospheric pressure in the analyzer vent**. Any back pressure on the detector vent connection can cause damage and require the replacement of the plasma detector module. However, the PED is a low-maintenance device that does not require regular upkeep.

#### 5.1.3. Electrical shock hazard

Do not operate unless the cabinet is securely closed. Servicing this instrument implies possible exposure to shock hazard level voltages which can cause death or serious injury.

For both safety and proper performance, this instrument must be connected to a properly

---

grounded three-wire source of electrical power.

Both alarm switching relay contacts and digital output contacts wired to a separate power source must be disconnected before servicing.

Tampering or unauthorized substitution of components may adversely affect the safety of this product. Use only factory-approved components for repair.

## **5.2. Analyzer application**

The LD8001 is specifically designed for analyzing impurities and samples as outlined in the instrument's specification sheet. Using this instrument with any **other gas type may cause damage** to the analyzer. To ensure safe and proper use, refer to the "Operating Parameters" document that accompanies the unit. It is important to note that the analyzer is not intended for use in hazardous areas.

## **5.3. Start-up**

To ensure the proper start-up of the LD8001, it is important to follow the steps below. All LDetek products are carefully packaged in a sturdy cardboard box, and each instrument is accompanied by a USB drive containing relevant documentation. If you require any assistance, please do not hesitate to contact us at [support@ldetek.com](mailto:support@ldetek.com).

1. Carefully unpack the instrument from the box and inspect it to ensure that it is in good condition and has not been damaged during shipping.
2. Locate the documents, USB drive, fuse kit and power cables.
3. Choose whether to install the unit on a table or mount it on a rack. If mounting on a rack, refer to section 8 for panel cutout drawings and to determine the required space.
4. Carefully install the instrument in its designated location and inspect it to ensure that it is in good condition and undamaged.
5. Remove all plugs from the back panel. do not forget to remove the plug on the detector vent connection as **pressurizing this instrument is strictly prohibited and can cause damage to the detector**.
6. Before connecting the sample line to the LD8001, make sure to purge it with Argon or Helium (depending on the application). The purging gas should have a minimum purity of grade 5.0 or better.
7. **Make sure that the plug on the sample vent was removed** and connect the sample line to the sample inlet of the LD8001. Note that a moisture trap (LDT-H2O-50) must always be installed on the sample inlet as shown on Figure 1. This trap is consumable and must be replaced every year.
8. If the LD8001 has an integrated stream selector, repeat steps 6 and 7 for the zero and

---

span inlets. The moisture traps must be installed as per the drawing on Figure 2.

9. Once the gas lines have been purged and connected, connect the power source. Check the "Operating Parameters" document to verify that the voltage is correct (either 120VAC or 240VAC), and make sure that the voltage indicated on the red indicator of the power inlet module on the back panel matches the voltage of the power source. **Using the wrong voltage source can cause severe damage to the instrument.**
10. Turn ON the unit by using the switch on the back panel and wait for the unit to boot.
11. Select the zero-gas stream on the LDGSS or on your stream selector. If the LD8001 has an integrated stream selector, the streams can be changed by following the procedure on section 7.2.4.
12. Once the sample flow established, the detector should turn on by itself after few minutes and start showing ppm readings.
13. Allow at least 24 hours of purging before calibrating the analyzer following the procedure on section 7.2.5.
14. Once the analyzer calibrated, compare the zero and span counts with the values in the calibration certificate provided with the LD8001.

#### **5.4. Shut-off**

If the system needs to be stopped for an extensive period, the connections on the back panel must be capped. Make sure that the sample, zero and span gases are closed before capping the analyzer because **any back pressure to the detector vent connections will damage the plasma detector modules**. Refer to the steps below to ensure the proper shut-off of the unit:

1. Turn OFF the LD8001 by switching the power switch located on the back panel.
2. Close the sample, zero and span gases by closing the cylinder or any valve that controls them. Note that the LDP1000 used for zero gas must be powered off according to the shut-off procedure explained in its manual.
3. Disconnect the sample inlet and sample outlet tubes from the analyzer back panel.
4. Install all the caps on the LD8001 back panel.

---

## **5.5. Typical installation**

The installation will vary depending on the LD8001 model. For analyzer without integrated stream selectors, please refer to Figure 1. For analyzer with an integrated stream selector, please refer to Figure 2 and for analyzers with the zero-gas free option, please refer to Figure 3.

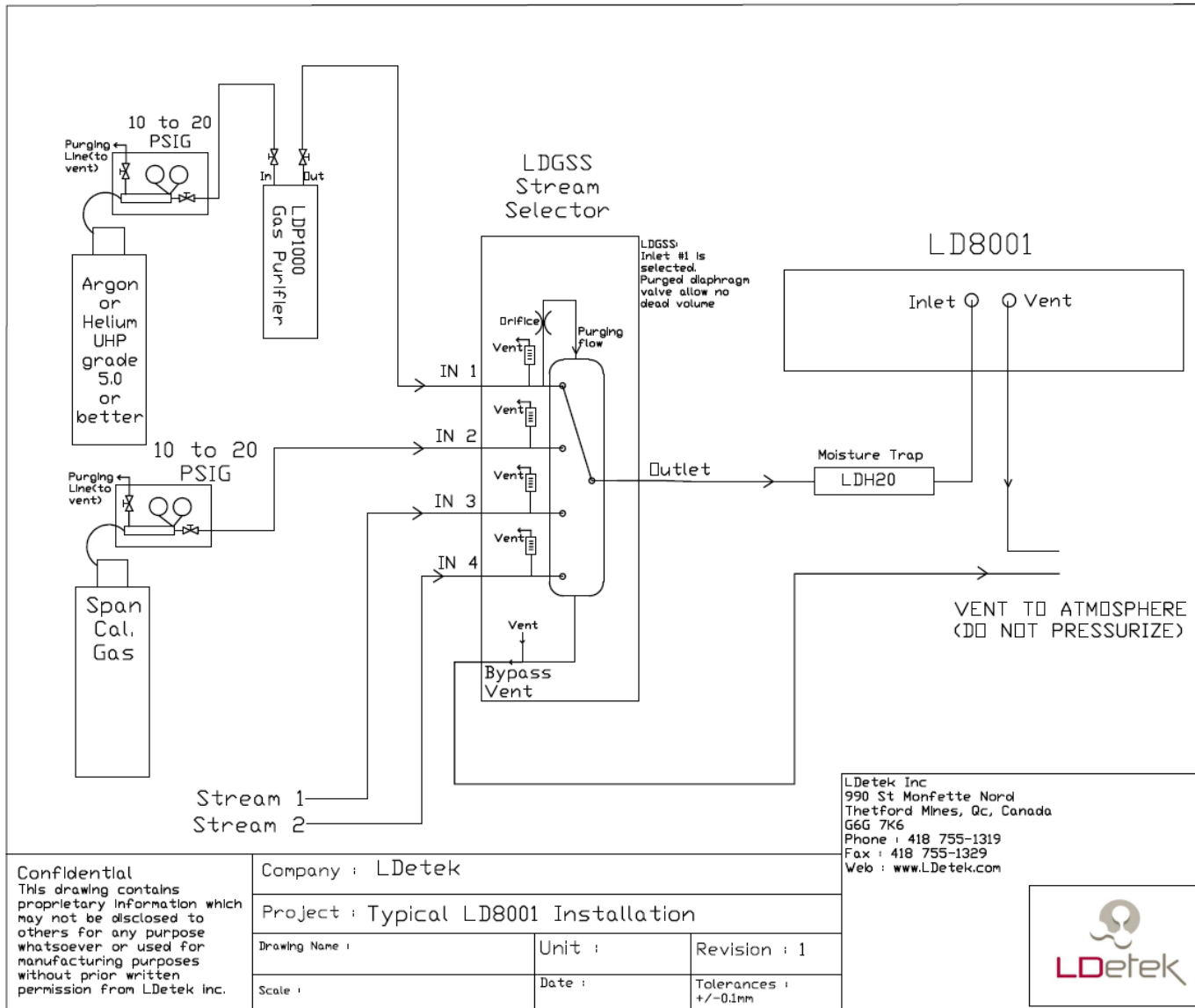

Figure 1: Typical Installation with LDGSS

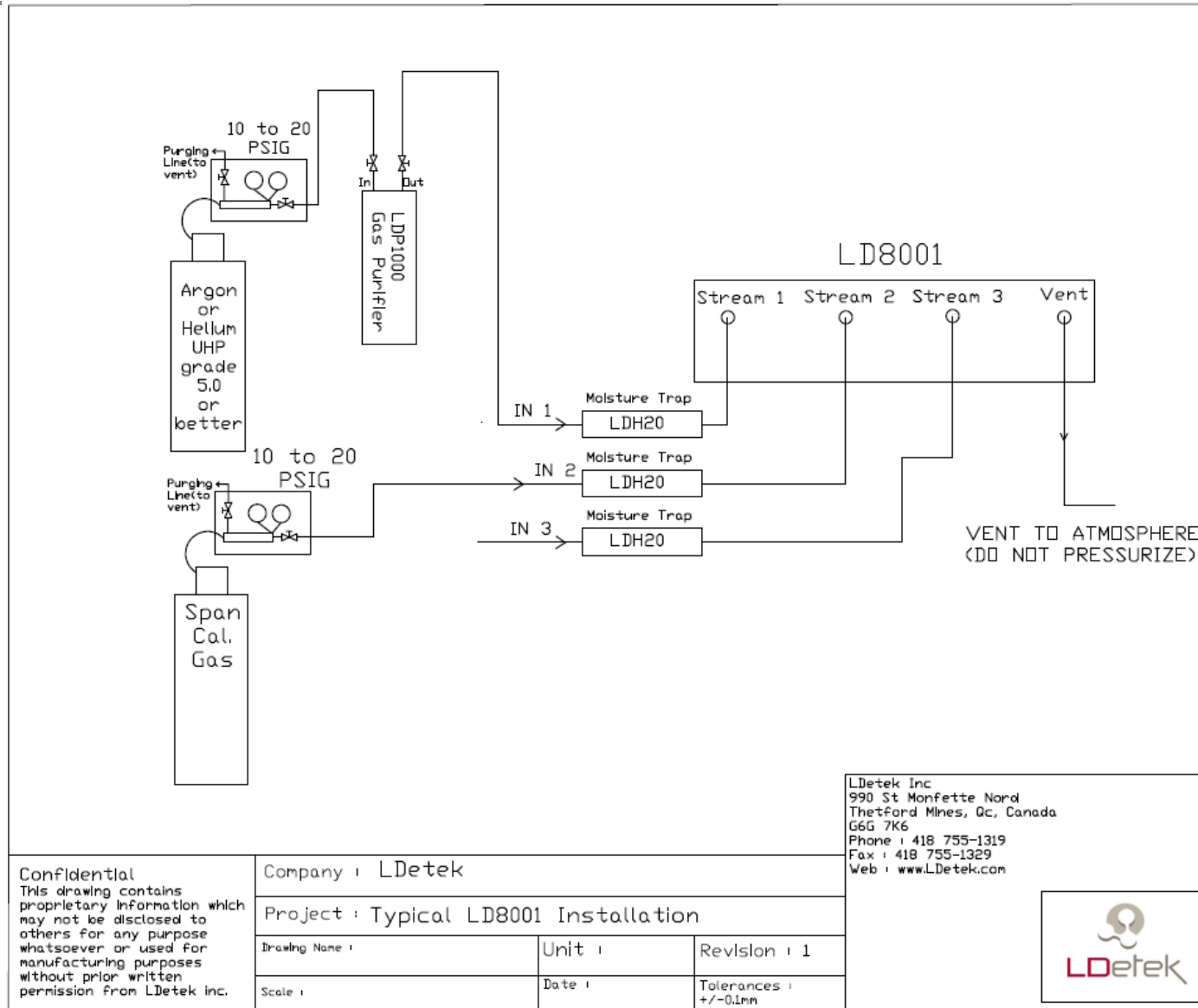

Figure 2: Typical Installation with integrated stream selector

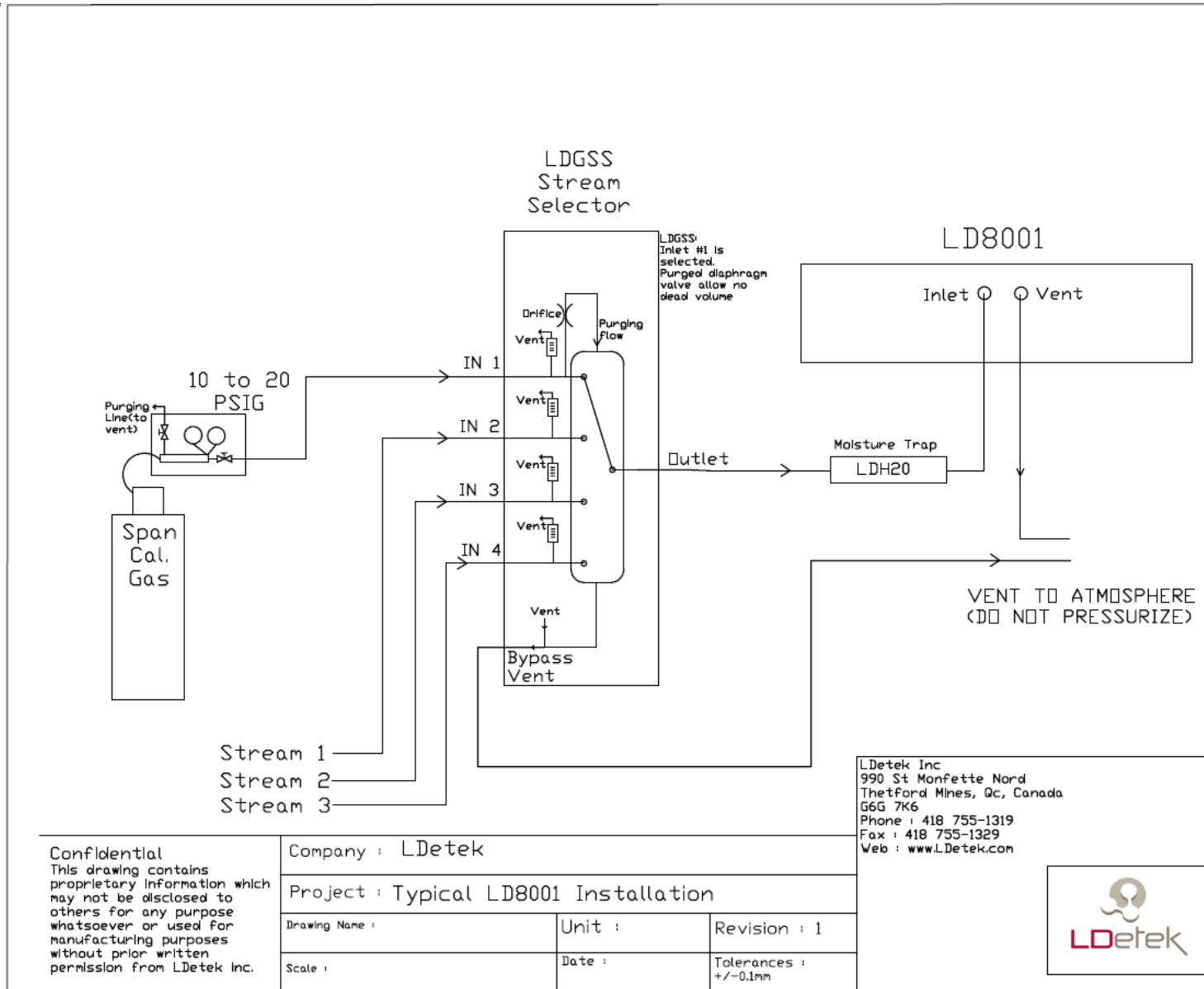

Figure 3: Typical Installation with zero gas free

---

## 6. Hardware description

The LD8001 has major components included in its chassis. This section will describe each component that can be replaced for maintenance or upgrade. Please refer to the Ordering section of this manual to get the part number for a replacement part. To order spare parts, please note the serial number of your unit and contact with LDetek factory at [support@ldetek.com](mailto:support@ldetek.com).

### 6.1. Detectors

The **PED** detector module is a 142 mm (6.6") x 107 mm (4.2") x 77 mm (3") box that contains all components needed to proceed to accurate measurement. This module is maintenance-free.

Two Compression 1/16" Stainless Steel Bulkhead types are used for connecting gas inlet and gas outlet to the Detector Module.



This module can be damaged if it has been pressurized or contaminated with inappropriate liquids or gases.



Figure 4: Type of Detectors

## 6.2. Motherboard

This motherboard controls all components inside the analyzer (e.g. flows, signals, LCD display, temperature, 4-20mA, etc.). It is comprised of the master board (MCU) as well as different sub modules. The master board communicate with these sub-modules through the bus board. Here are the submodules that can be replaced:

- Plasma board: Used to control the detector and HCD
- Flow board: Used to control the flows, 4-20mA and relays
- Oven board: To control the zero-gas free purifier

These boards must be replaced only with LDeftek's confirmation as there are risk for an electrical shock hazard.

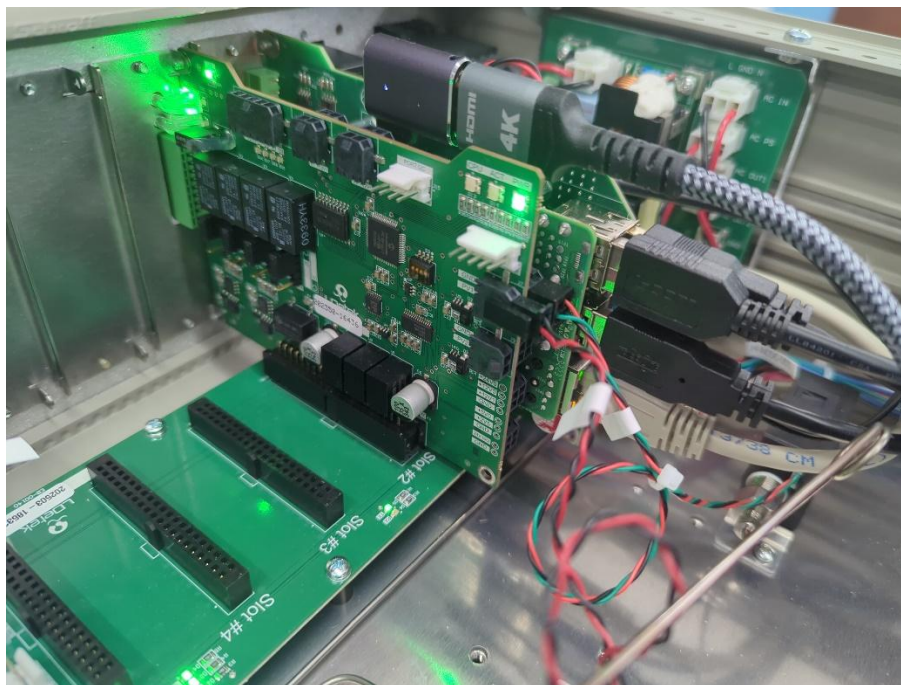

Figure 5: LD8001 printed circuit board (PCB)

### 6.3. Sample gas proportional valve

This valve plays a crucial role in controlling sample flow within the instrument, featuring a very low dead volume design that enables rapid purging times at start-up and fast flow stabilization.

Designed by LDetek, this valve is specifically engineered to provide excellent stability and minimize contamination risks when operating at ppb levels. Additionally, it can be ordered as spare part, and its compact size makes it easy to replace on-site with minimal disruption.

The standard LD8001 operates within a recommended pressure range of 3 psig to 30 psig. Operating pressures above this range may damage the valve, leading to instability or failure to close completely. In such cases, replacement of the valve is necessary to ensure reliable instrument operation.



Figure 6: Solenoid proportional valve

### 6.4. Display with Touch Screen (7" 800x480)

This 7" display allows having a user's friendly interface. Moreover, its touch screen allows easy navigation through the different menus. Carefully handling the touch screen is essential to ensure not damaging it.



If the display is damaged, it can be easily replaced by removing the back plate of the door and the four fixing screws. A new display can be ordered from LDetek.

### 6.5. Serial port

As shown on section 8.3, the LD8001 comes with a RS-232/RS485 port that can be used for communications. Note that Modbus is only available as an option.

### 6.6. Relays

The LD8001 comes standard with 4 relays. They are N.O. but can be configured as N.C. By default, Relay 1 is assigned to status and Relays 2 and 3 are assigned to ranges. The function for each relay can be modify. Feel free to contact us at [support@ldetek.com](mailto:support@ldetek.com) for more details.

### 6.7. 4-20mA module

As an option, the LD8001 comes with a 4-20mA output. The bellow figure shows the connections, and additional details can be found on section 8.3.

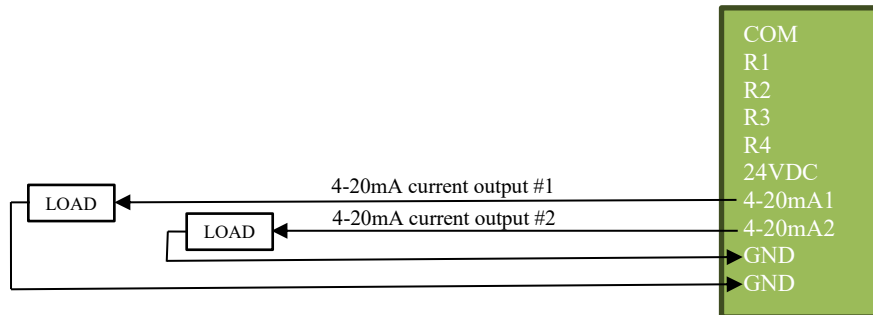

## 7. Operation

### 7.1. User interface

This section will try to show the user interface. Feel free to contact LDefetek at [support@ldetek.com](mailto:support@ldetek.com), if you need clarifications.

#### 7.1.1. Analysis menu

The Analysis Menu displays real-time information about the analyzer, allowing users to monitor its performance and status.

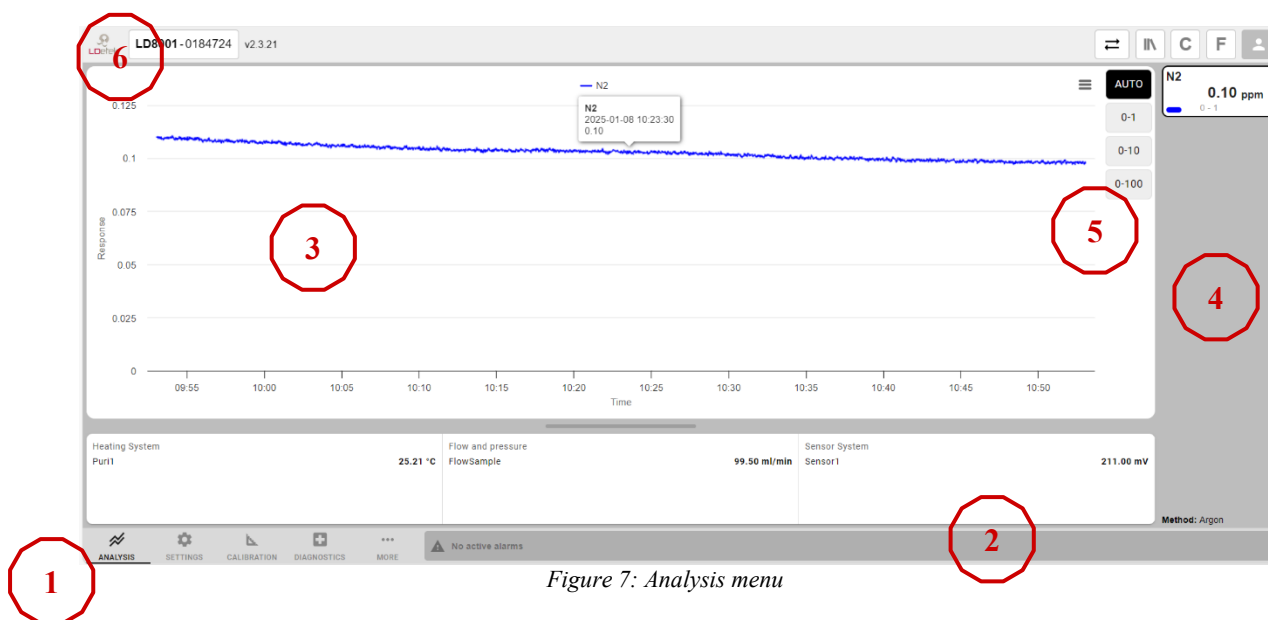







Figure 7: Analysis menu

1. **Left Bottom Bar:** This bar allows you to switch between different menus. The buttons enable you to navigate to the Analysis, Settings, Calibration, Diagnostics, and More menus respectively.
2. **Right Bottom Bar:** This bar provides vital information about alerts on the LD8001. The color of the bar changes to red when one or more alarms are active and yellow when there is a warning. If the bar is gray, it indicates that there are no alarms, and the system is ready for analysis. Double-clicking on the bar will open the Alarms Menu, where users can view detailed information about the alerts, including their type and the date they occurred.
3. **Graphic:** This section shows real-time data from the analyzer, with the X-axis indicating time and the Y-axis representing concentration. You can zoom in by clicking and dragging a box, and un-zoom by right-clicking.
4. **Side bar:** The top section displays the real-time concentration of N<sub>2</sub>. The bottom part of the side bar shows information about the method and stream being used.

5. **Range Selection:** Change the scale of the Y-axis. When set to “Auto,” the Y-axis will adjust automatically based on the impurity concentration.
6. **Top-Left Corner:** This area shows the instrument serial number and software version. By clicking on the serial number, you can enter the About Menu.
7. **Top-Right Section:** This section displays icons that indicate the status of the analyzer.
  - a. When colored, the first icon  indicates that the communication between the software and firmware is established.
  - b. The second icon  indicates that the connection between the software and LDReport is established.
  - c. The third icon  indicate that a calibration is being performed using presets. By clicking on this icon, it is possible to stop a calibration.
  - d. The fourth icon indicate that a force has been applied to the analyzer. By clicking on this button, it is possible to reset these forces: .
  - e. The fifth icons indicate the login information. When grey, it means that the analyzer is in user mode . When showing “AD”, it means that the analyzer is in admin mode. By clicking on this button, it is possible to switch between user and admin mode.

### 7.1.2. Settings menu

The settings menu is where all the system parameters can be accessed. However, it is important to note that making changes to these settings without proper knowledge and guidance can negatively impact system performance. Therefore, any changes made to the settings in this category should only be done after consulting with LDetek support. Furthermore, the available settings may vary depending on the software version installed. To update the software, please contact LDetek support to ensure compatibility with your system.



Figure 8: Settings menu

**General:** This section displays general settings like graphic duration.

**Device:** This section displays general device settings like tag name.

**Method:** This section displays settings related to the methods configured within the analyzer.

**Streams:** This section displays settings for analyzers with an integrated stream selector.

**Plasma:** This section displays settings related to the plasma emission detector.

**Sensor:** This section displays settings related to the sensors installed in the detector.

**Flow:** This section displays settings related to the flows.

**Relay:** This section is where we can find settings for the relays.

**4-20mA:** This section displays settings for analog outputs.

### 7.1.3. Calibration menu

The calibration menu is where the calibration can be done.

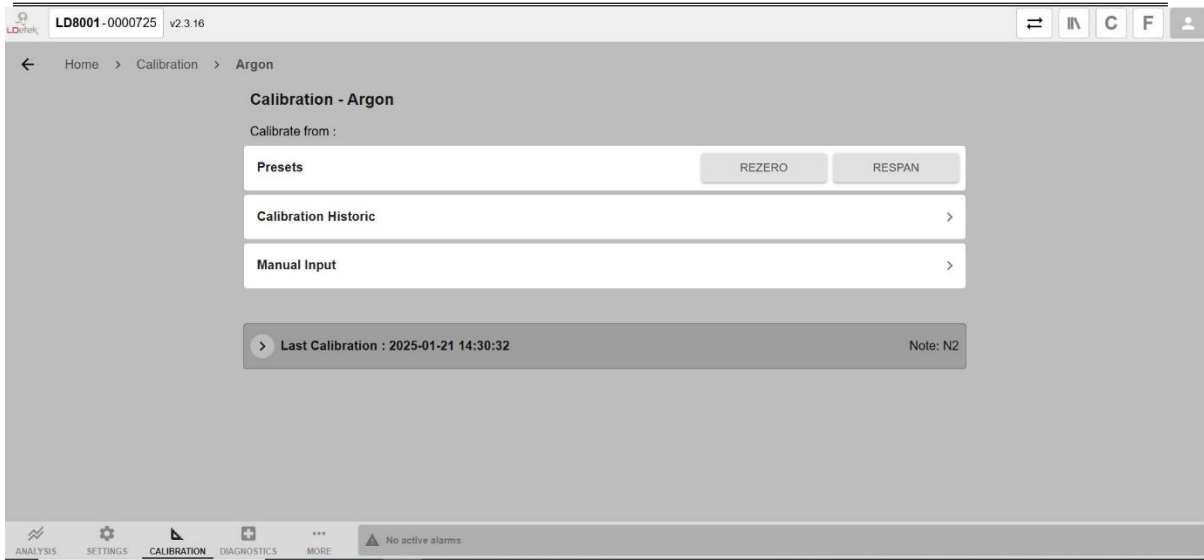

Figure 9: Calibration menu

**Preset:** This section allows you to configure presets for automatic calibration. This is explained in detail in section 7.2.6.

**Calibration Historic:** This section will show you details about previous calibrations done on the analyzer.

**Manual Input:** This section allows you to do a manual calibration. This is explained in detail in section 7.2.5.

**Last Calibration:** This section displays details about the last calibration.

#### 7.1.4. Diagnostic menu

This section displays the real-time values of the most critical components in the instrument. It allows you to validate whether the instrument components such as the relay, and the 4-20mA module are operating optimally. By monitoring these values, you can quickly identify any irregularities or potential issues that may affect the performance of the instrument.

In addition to monitoring, the Diagnostics Menu provides the capability to force or unforce any component such as relays, 4-20mA, etc. This means you can manually activate or deactivate specific components to assess their functionality or to troubleshoot issues. For example, if you suspect a component is not working correctly, you can force it to operate and observe its behavior in real-time.

Furthermore, the Diagnostics Menu offers detailed information and status updates for each component, helping you make informed decisions about maintenance and repairs.

Overall, the Diagnostics Menu is an essential tool for maintaining the reliability and efficiency of the instrument, providing both real-time monitoring and control capabilities.

### Diagnostics

Flow Board1-0x1C9F15000BA30400

MASTER/SLAVE

<b>4-20mA1</b> Analog Output	Value	19.68 mA	<input type="button" value="FORCE VALUE"/>
	Ratio	79.05 %	<input type="button" value="FORCE RATIO"/>
<b>Relay1</b> Digital Output	OFF	<input type="button" value="FORCE ON"/>	<input type="button" value="FORCE OFF"/>
<b>Relay2</b> Digital Output	OFF	<input type="button" value="FORCE ON"/>	<input type="button" value="FORCE OFF"/>
<b>Relay3</b> Digital Output	ON	<input type="button" value="FORCE ON"/>	<input type="button" value="FORCE OFF"/>
<b>Relay4</b> Digital Output	OFF	<input type="button" value="FORCE ON"/>	<input type="button" value="FORCE OFF"/>
<b>Flow1</b> Analog Input	Filtered value	693.25 mV	
	Unit value	100.41 ml/min	
<b>FlowCtrl1</b> Analog Output	Value	5327.83 mV	<input type="button" value="FORCE VALUE"/>
	Ratio	53.28 %	<input type="button" value="FORCE RATIO"/>
<b>Sensor1</b> Analog Input	Filtered value	7497.12 mV	
	Unit value	7497.12 mV	
<b>PlasmaPower1</b> Analog Output	Value	7368.75 mV	<input type="button" value="FORCE VALUE"/>
	Ratio	60.00 %	<input type="button" value="FORCE RATIO"/>

Figure 10: Diagnostic menu

### 7.1.5. More menu

In this section, you will have access to additional information and settings for various parameters of the device. The More Menu provides several important functionalities that enhance the usability and customization of the instrument.

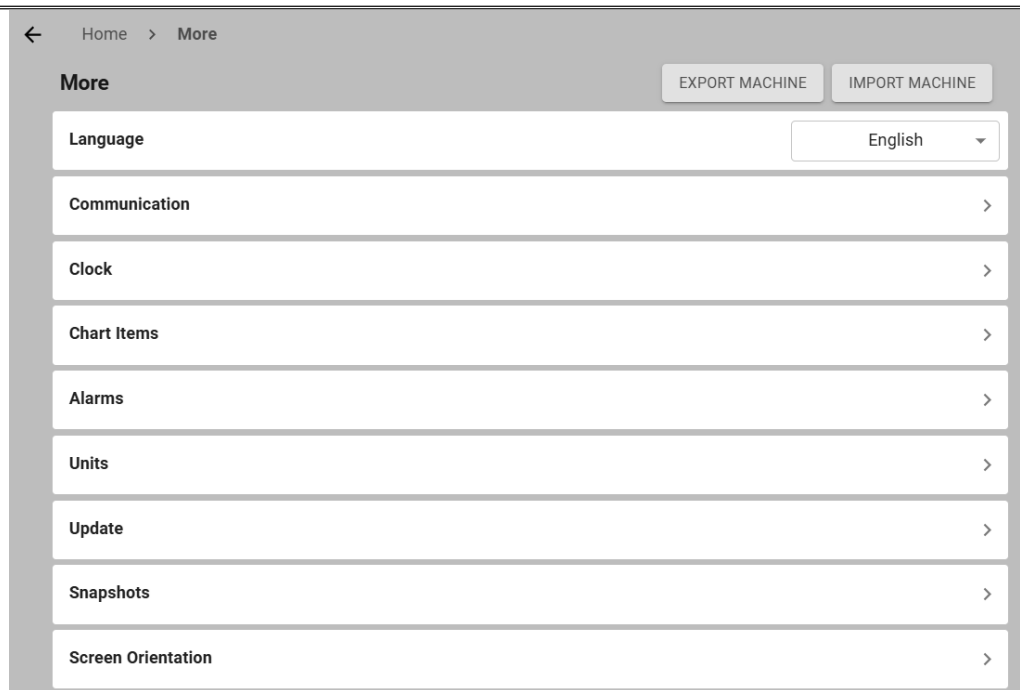

Figure 11: More menu

**Export/Import Machine:** This section allows users to import and export a machine file. This can be used to backup the data on an external drive.

**Language:** This section allows users to change the language of the interface.

**Communication:** This section allows you to configure Modbus communication settings.

**Clock:** This section allows you to set and adjust the device's clock.

**Chart Items:** This section allows you to hide/show items such as flows and temperatures on the graphic.

**Alarms:** This section is the Alarms menu and can also be access by double-clicking on the right-bottom bar.

**Unit:** This section allows you to change the unit (e.g. flow, temperature, pressure, etc.).

**Alarms:** This section is the Alarms menu and can also be access by double-clicking on the right-bottom bar.

**Update:** This section allows you to update the software.

**Snapshot:** This section allows you to take a snapshot to save the current setting and load an old snapshot if needed.

**Screen Orientation:** This section allows you change the screen orientation.

## 7.2. Software procedures

This section will show a few procedures that can be helpful while using the LD8001. Feel free to contact us at [support@ldetek.com](mailto:support@ldetek.com) if you have any questions.

### 7.2.1. How to switch from the user to the admin mode

1. If you are in user mode, the login button on the top-right corner will be grey. Click on this button to switch to the admin mode.



2. The login menu will open then enter the username and password and click on login. By default, the username is “admin”, and the password is “12345”.

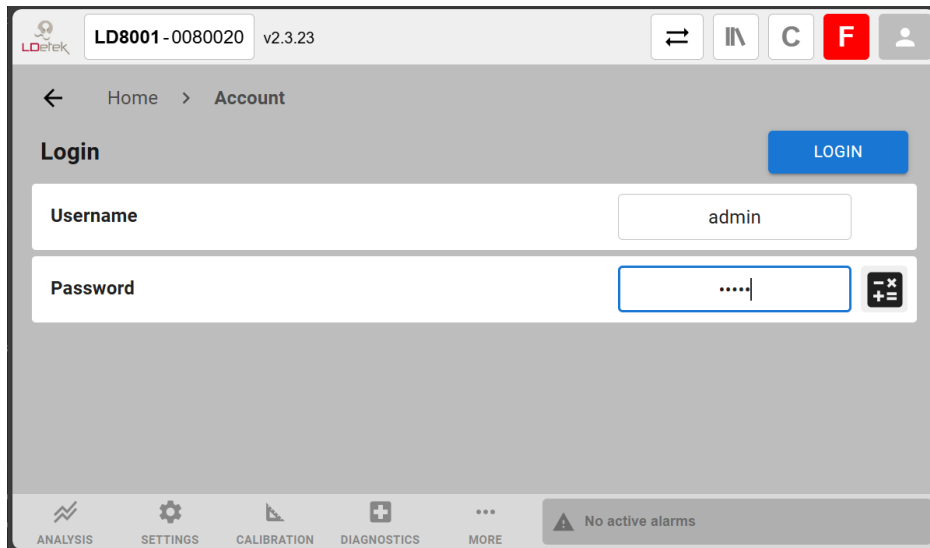

3. You can confirm that you have enter the admin mode by looking at the top-right corner. The login button will display “AD”.



### 7.2.2. How to switch from the admin to the user mode

1. If you are in admin mode, the login button on the top-right corner will be greed and showing “AD”. Click on this button to switch to the user mode.

- The account menu will open then click on Logout.

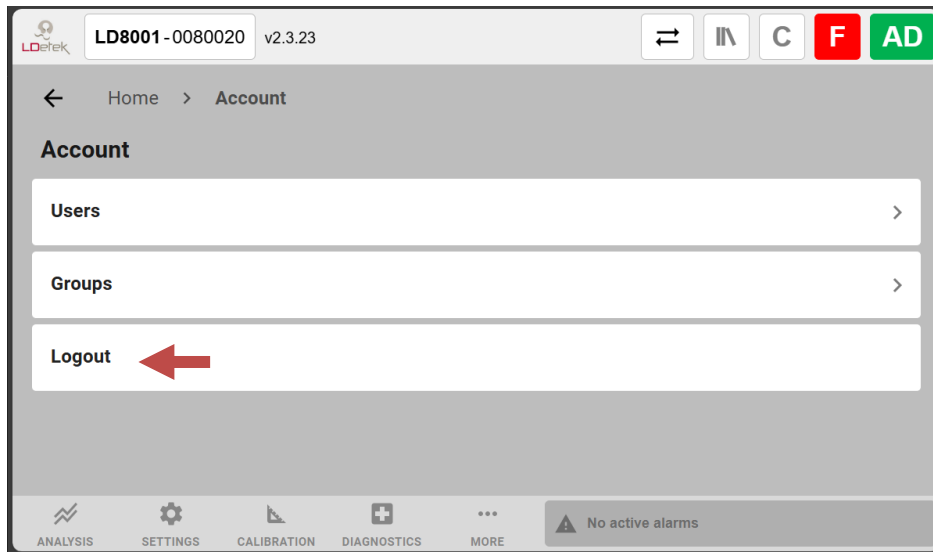

- You can confirm that you have enter the user mode by looking at the top-right corner. The login button will be grey.



### 7.2.3. How to switch between methods

- If the analyzer is configured for dual background, the method can be changed form the main menu. To do so, click on “method” located on the bottom-right corner above the alarm button.
- A slider will open, then click on “Method”.

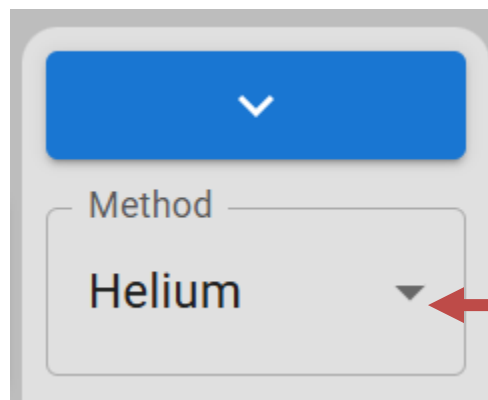

- A drop-down menu will open allowing you to select the method you want. The selected method will be shown on the bottom-right corner of the main menu.

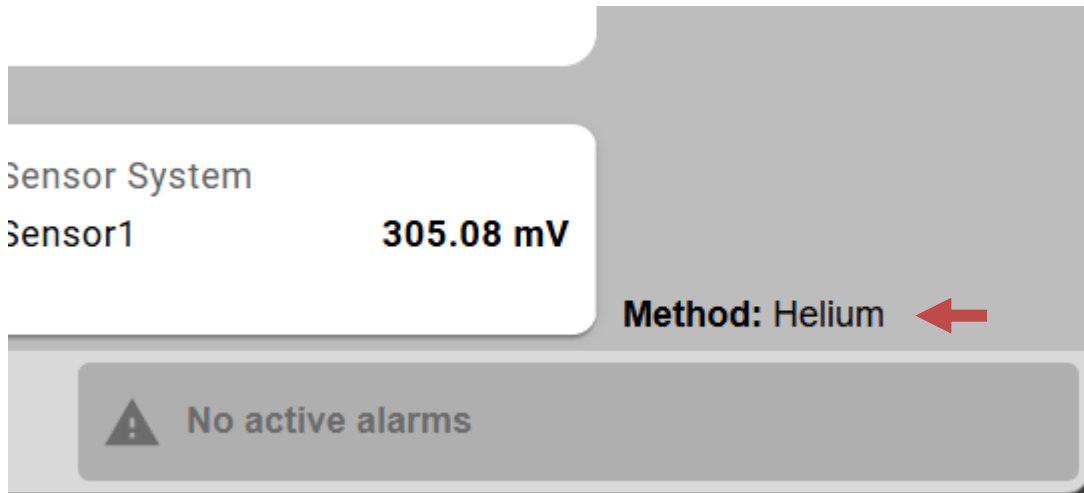

#### 7.2.4. How to switch between streams

1. If the analyzer is configured with an integrated stream selector, streams can be changed from the main menu. To do so, click on “stream” located on the bottom-right corner above the alarm button.
2. A slider will open, then click on “Stream”.

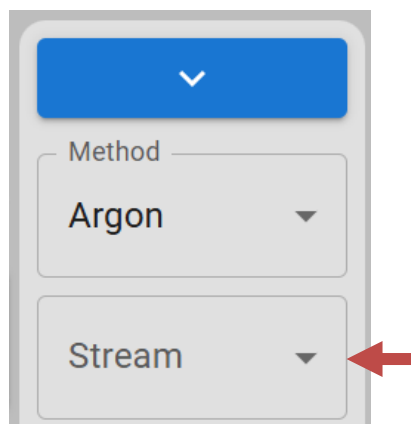

3. A drop-down menu will open allowing you to select the stream you want. The selected stream will be shown on the bottom-right corner of the main menu.

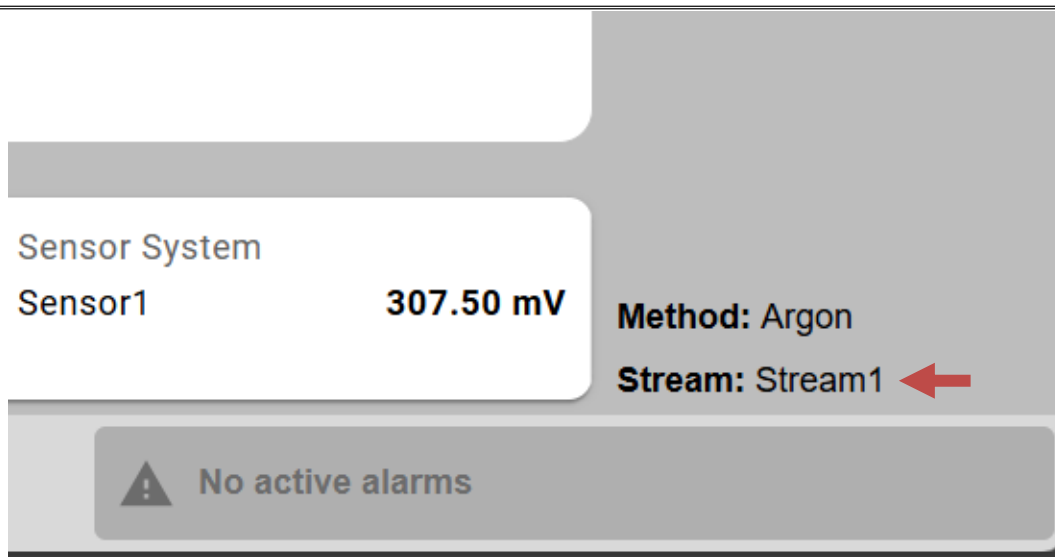

### 7.2.5. How to manually calibrate the LD8001

1. Follow the procedure on section 7.2.1 to switch to the admin mode.
2. If your analyzer is dual background (Helium and Argon), select the method that you want to calibrate by following the procedure on section 7.2.4. Otherwise, skip to the next step.
3. Select the zero-gas stream and let it flow for 30 minutes. When using an LDGSS, the stream can be selected manually from the LDGSS's front panel. When the LD8001 comes with an integrated stream selector or the zero-gas free option, the stream can be selected by following the procedure on section 7.2.4. After 30 minutes, the ppm reading should be stable, and you can proceed for calibration.
4. Click on the calibration button, select the method that you want to calibrate and click on "Manual Input".

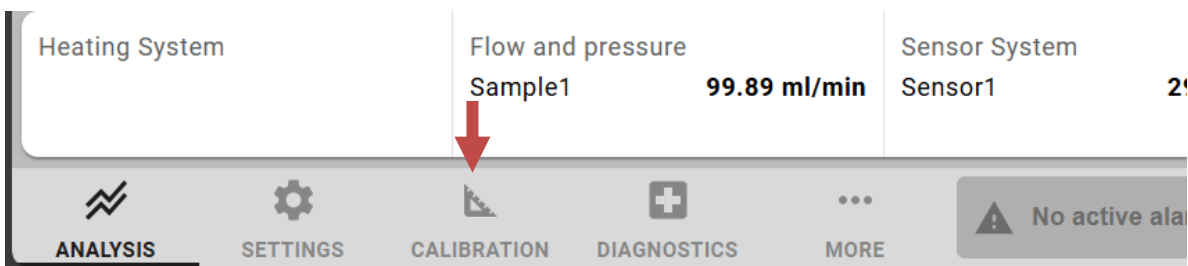

5. Go to the zero section and make sure that the ppm concentration matches you zero gas. Then, click on the arrow to update the \_cnt value.

**ZERO**

	_cnt		ppm
<b>Current calibration</b>	1987.45	→	0.00
<b>New calibration</b>	974.71	→	0

6. Click on the “apply” button located at the top of the page.

Helium > **Manual Input**

EXPORT CALIB    CANCEL    **APPLY**

7. A window will open allowing you to review the change. If the \_cnt and concentration are fine, click on “Apply” to save the changes.

LD8001-0080020 v2.3.23

**Calibration modification for Helium**

Calibration note: N2

Impurity	Old value	New Value	Apply to	
N2	1987.45 _cnt 10000.00 _cnt	0.00 ppm 10.00 ppm	974.71 _cnt 0.00 ppm 10000.00 _cnt 10.00 ppm	<input checked="" type="checkbox"/>

CANCEL    **APPLY**

8. With the zero-calibration done, we can now calibrate the span. Select the span-gas stream and let it flow for 30 minutes.
9. Click on the calibration button, select the method that you want to calibrate and click on “Manual Input”.
10. Go to the span section and make sure that the ppm concentration matches the cylinder COA. Then, click on the arrow to update the `_cnt` value.

**SPAN**

	<code>_cnt</code>	→	ppm
<b>Current calibration</b>	10000.00	→	10.00
<b>New calibration</b>	9465	→	9.43

11. Click on the “apply” button located at the top of the page.
12. A window will open allowing you to review the change. If the `_cnt` and concentration are fine, click on “Apply” to save the changes.
13. If your analyzer is dual background, repeat step 3 to 12 for the second method.

### 7.2.6. How to automatically calibrate the LD8001 with presets

Presets can be used to configure calibration parameters. For instance, we can create a preset for zero calibration that will automatically select the stream, purge it and do the calibration. Here are the steps to create presets.

1. Follow the procedure on section 7.2.1 to switch to the admin mode.
2. Click on the calibration button, select the method and click on “Presets”.
3. Click on the “+” to add a new preset.
4. From that menu, you can name the preset and chose its function. For zero calibration, select “Standard ReZero”, and for span, select “Standard ReSpan”. If your analyzer is zero-gas free, select “Zero Gas Free” instead of “Standard ReZero”.

**Preset1**
CANCEL
APPLY

<b>Preset name</b>	Preset1
<b>List Order</b>	1
<b>Communication ID</b>	1
<b>Function</b>	Standard ReZero ▾

5. Make sure that N2 is enable and select the stream. For LD8001 without integrated stream selector, you can leave this field blank. When calibrating with the preset, you will have to manually select the stream on your stream selector.

**Select Impurities**

N2

<b>Stream to select</b>	Stream1 ▾
<b>Time to purge</b>	1800 s
<b>Time for reading</b>	10 s

6. The enter the purge time. Note that LDefek recommend 1800 seconds (30 minutes).
7. Enter the “time for reading”. If it is set to 10 seconds for instance, the analyzer will average the reading for 10 seconds before doing the calibration.
8. Click on the “apply” button located at the top of the page.
9. Once the preset created, you can initiate it by going to Home > Calibration > [Method] and pressing the preset button.



10. Once the calibration started, the right-bottom bar will show you the remaining time before calibration.

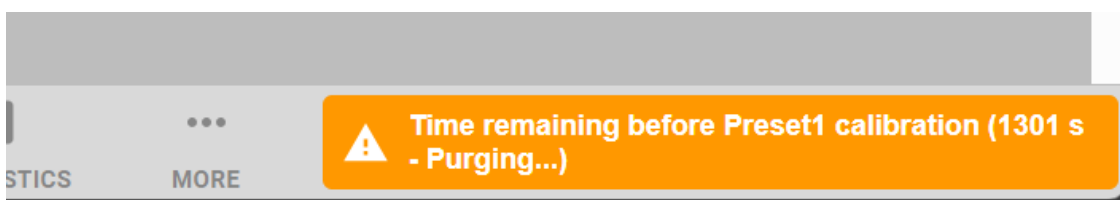

### 7.2.7. How to remotely access the LD8001 web interface

When connected to a network, the LD8001 web interface can be accessed from a web browser. This allows you to control, monitor, and troubleshoot the analyzer remotely. Follow the steps below to access the web interface:

1. Click on the analyzer's serial number located in the top-left corner of the screen to open the About Menu.
2. In the About Menu, locate and note the analyzer's IP address.
3. On a computer that is connected to the same network as the analyzer, open a web browser.
4. In the web browser's address bar, type the LD8001's IP address and press Enter.
5. The web browser should now display the LD8001 user interface, allowing you to control, monitor, and troubleshoot the analyzer remotely.

### 7.2.8. How to export a machine file

1. Click on the "More" button located in the bottom-left bar of the screen to open the More Menu.
2. In the More Menu, click on "Export Machine".
  - a. When done from the analyzer, the machine file will be saved locally.
  - b. When done from the web interface, the machine file will be saved on the remote computer.

---

### 7.2.9. How to import a machine file

1. Follow the procedure on section 7.2.1 to switch to the admin mode.
2. Click on the “More” button located in the bottom-left bar of the screen to open the More Menu.
3. In the More Menu, click on “Import Machine”.
4. Import the machine file located on the analyzer or on the remote computer.

### 7.2.10. How to change the impurity range

1. Follow the procedure on section 7.2.1 to switch to the admin mode.
2. On the side bar, click on the N2 concentration.
3. A new window will pop-up asking you to select the range of measurement that you want. Select the desired range and press “Apply”.

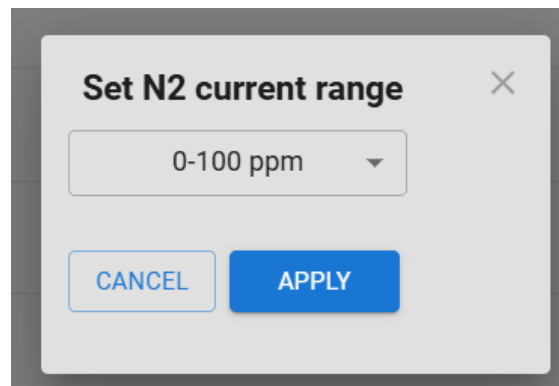

---

## 8. Drawings & Schematics

## 8.1. Part Identification

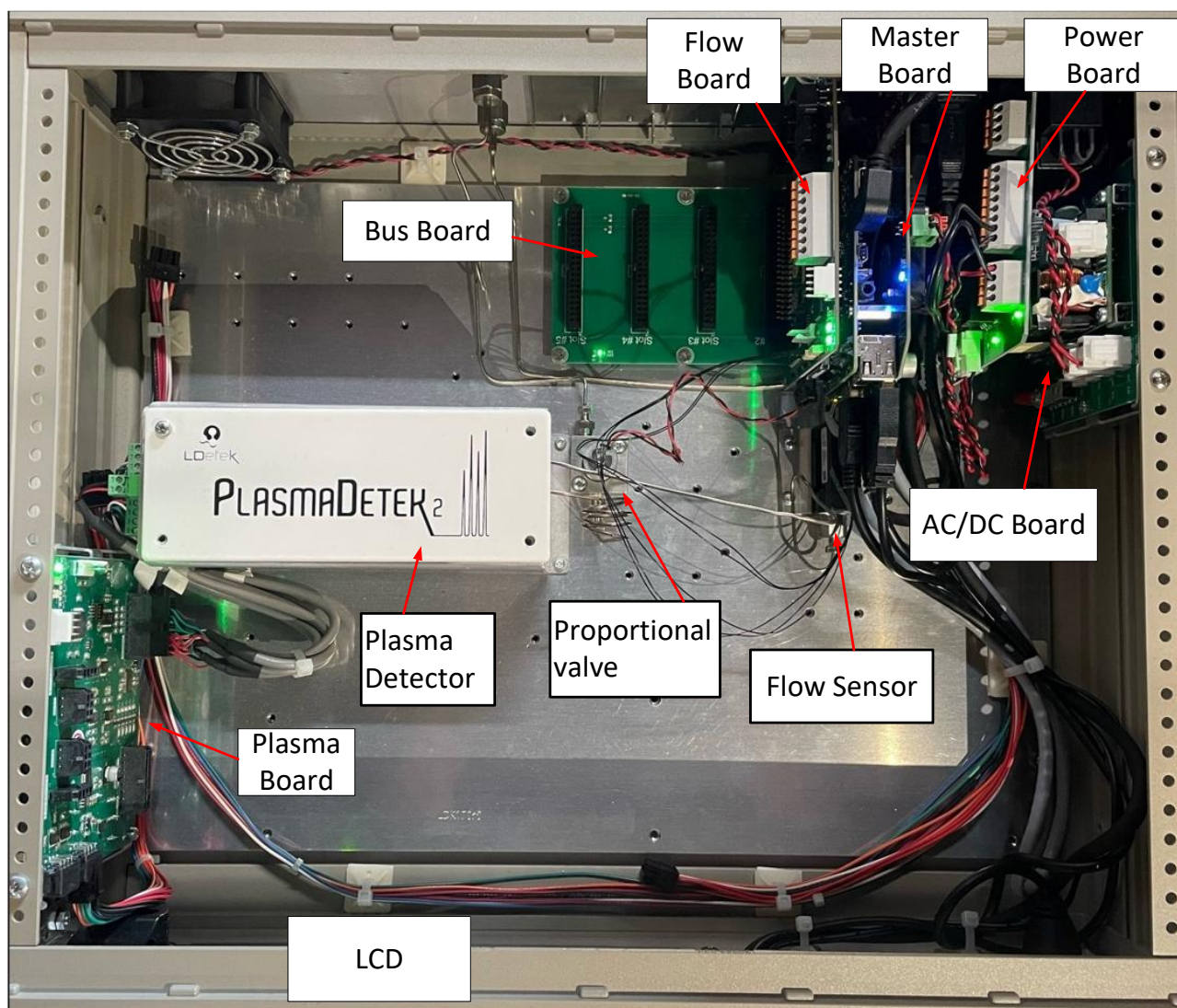

## 8.2. Back Panel Identification

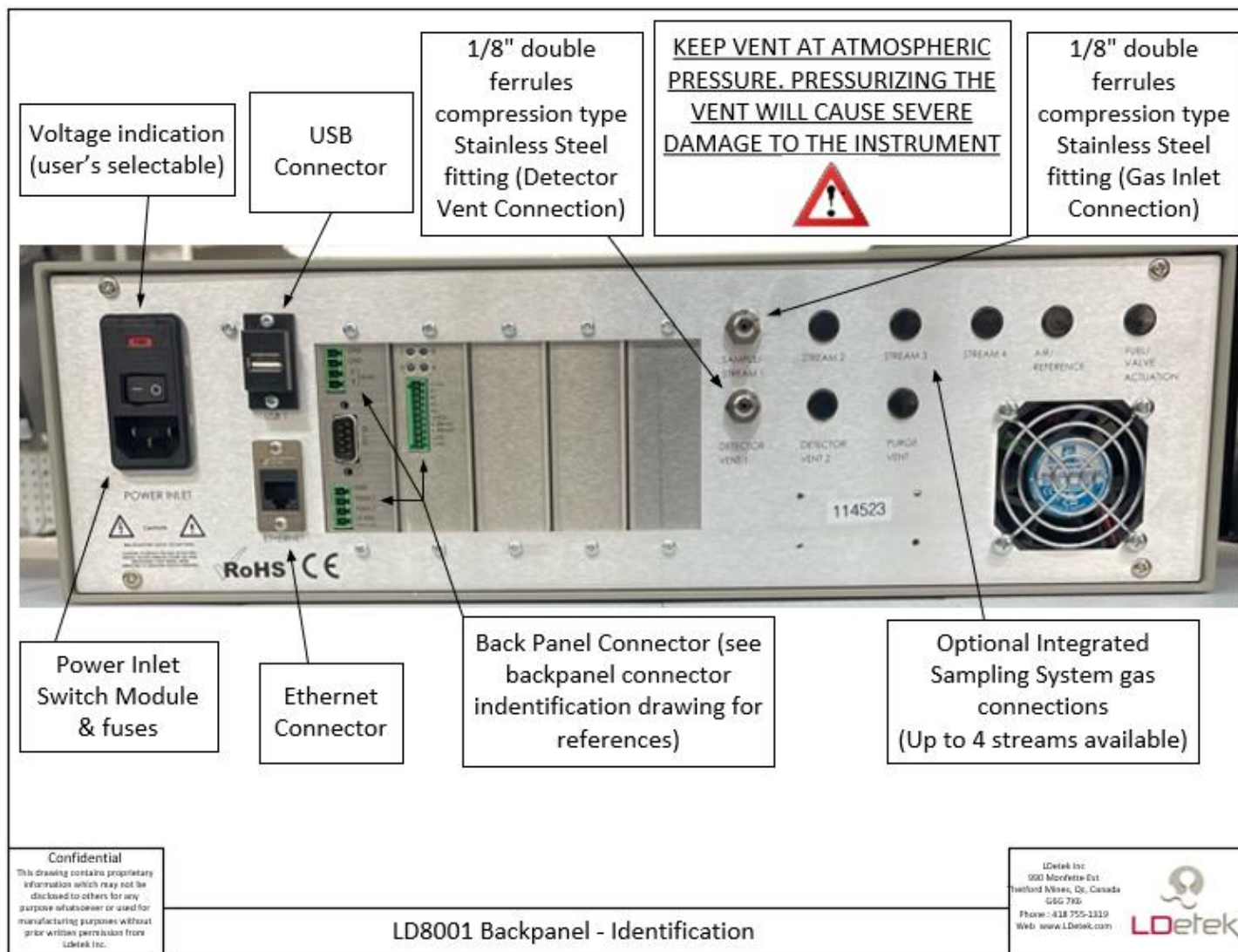

### 8.3. Back Panel pins Identification

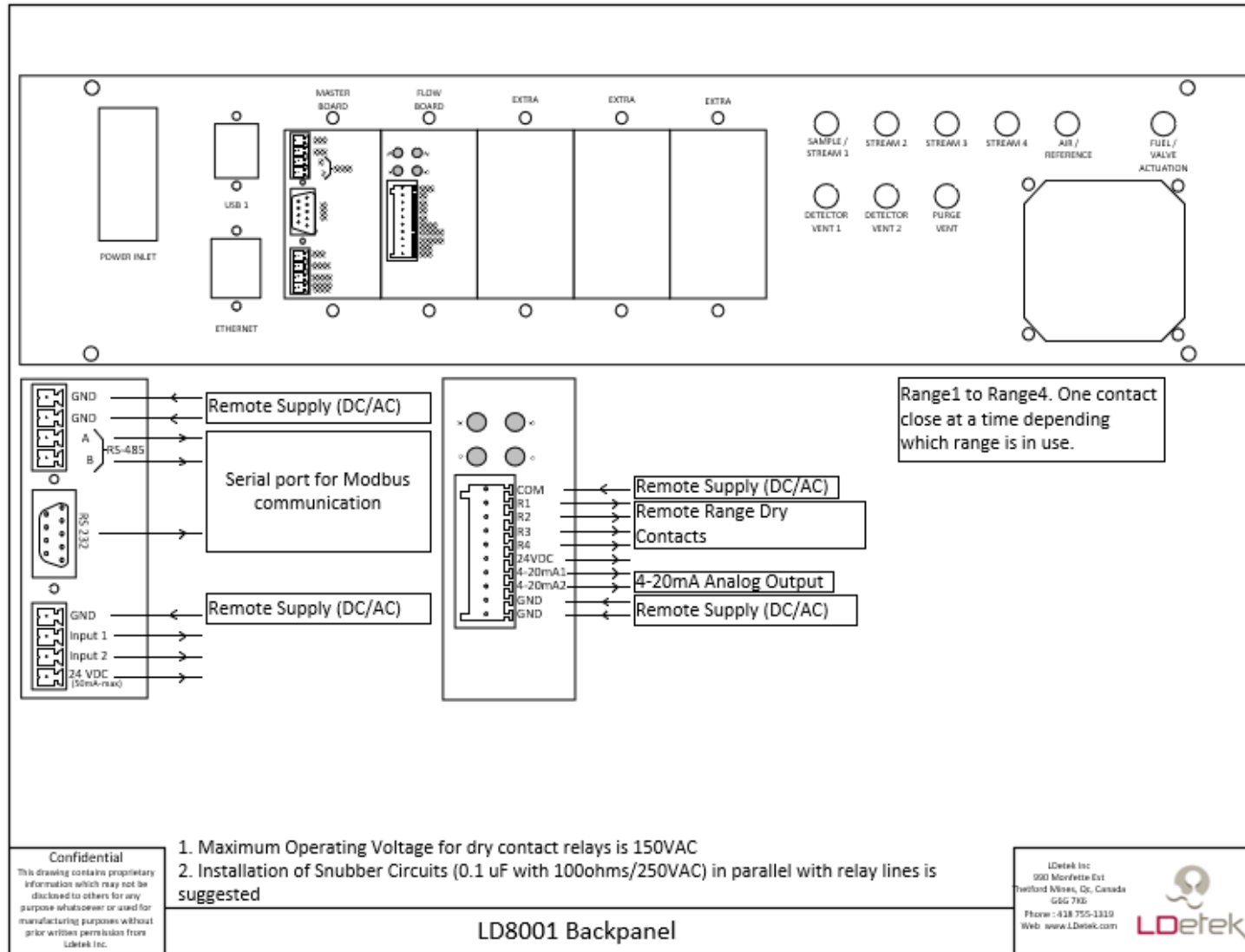

### 8.4. Electrical schematic (block diagram)

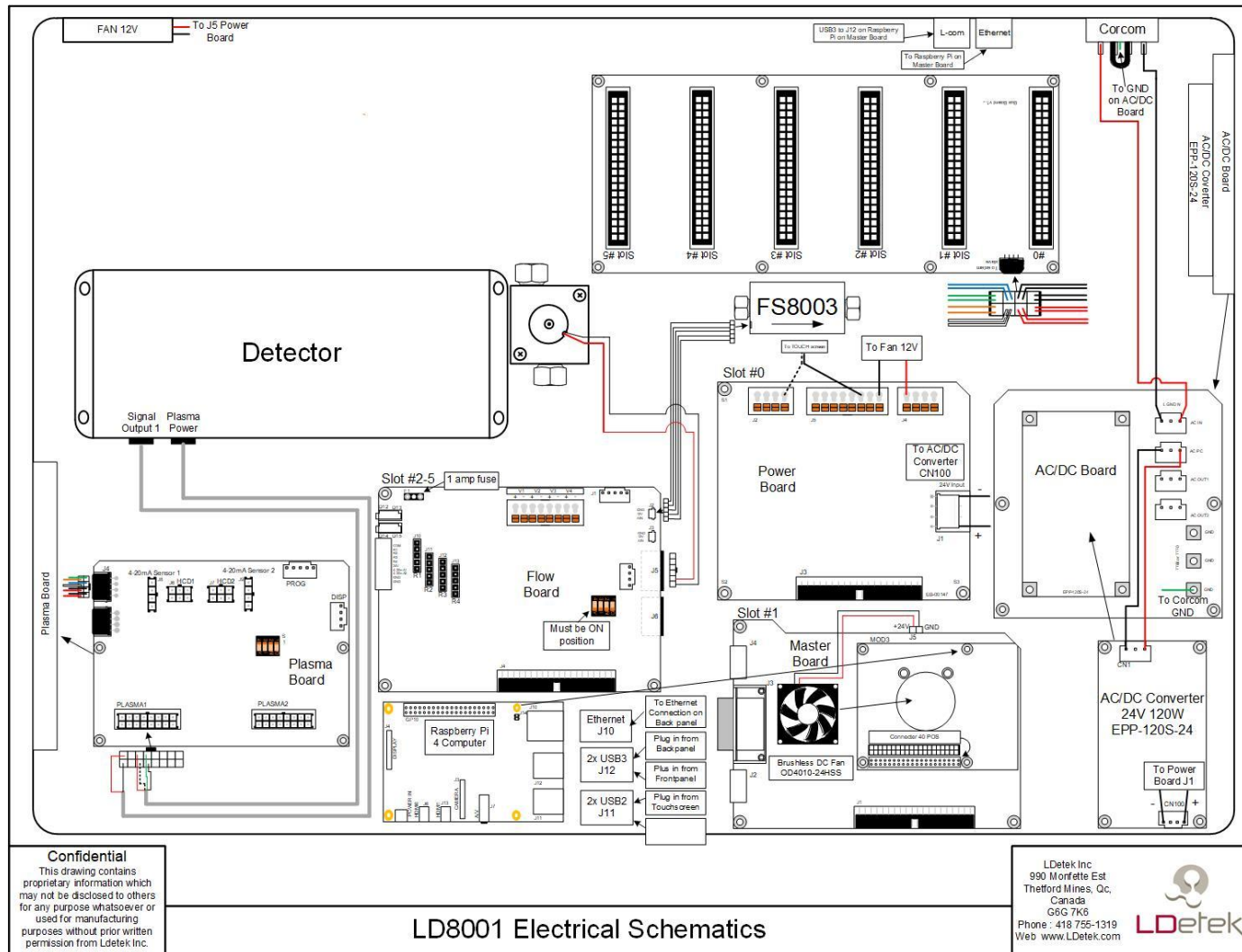

### 8.5. Electrical schematic (internal view)

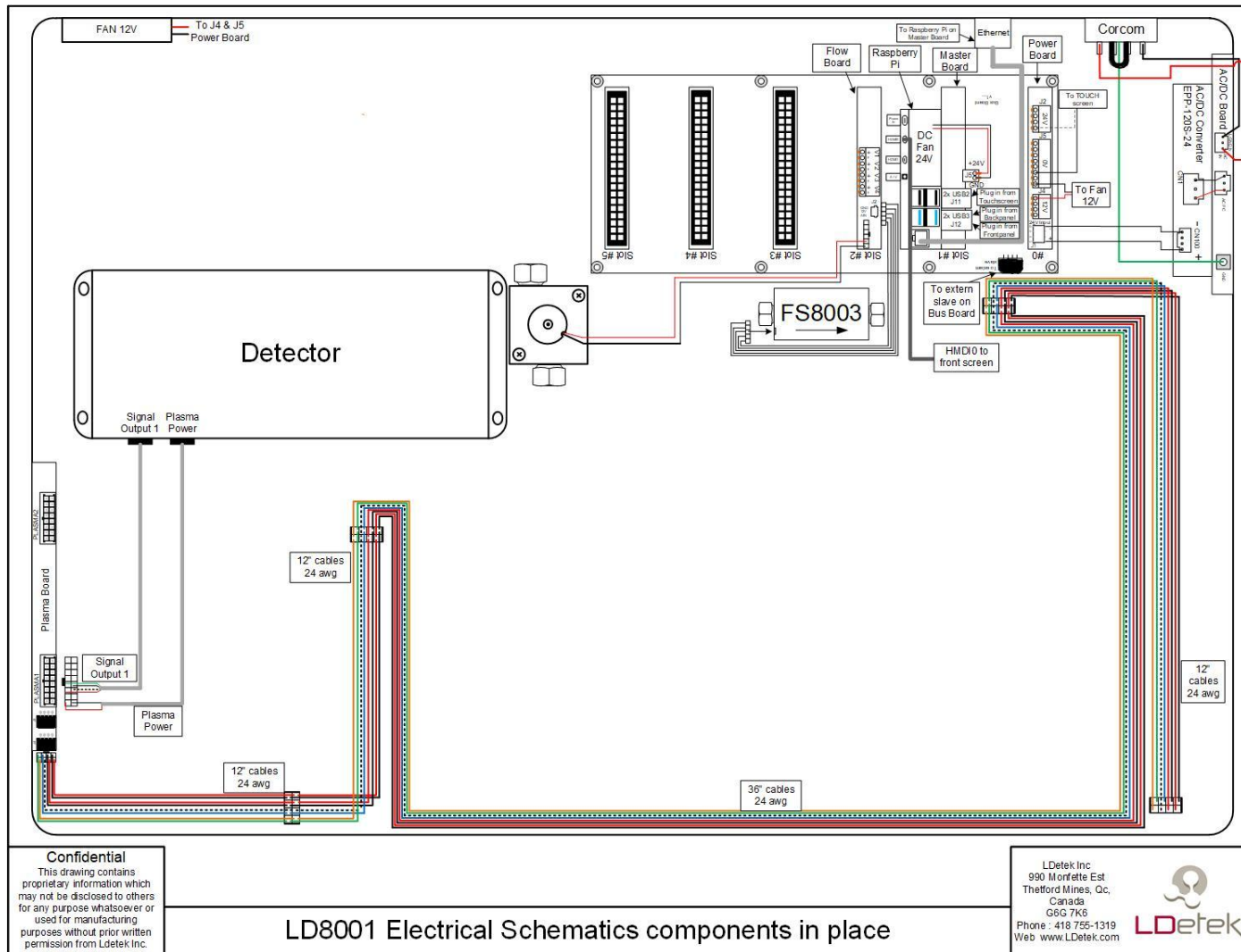

**Confidential**  
This drawing contains proprietary information which may not be disclosed to others for any purpose whatsoever or used for manufacturing purposes without prior written permission from Ldetek Inc.

LD8001 Electrical Schematics components in place

Ldetek Inc.  
990 Morfette Est  
Theford Mines, Qc.  
Canada  
G6G 7K6  
Phone : 418 755-1319  
Web www.Ldetek.com

## 8.6. Enclosure Dimensions & Panel Cutout

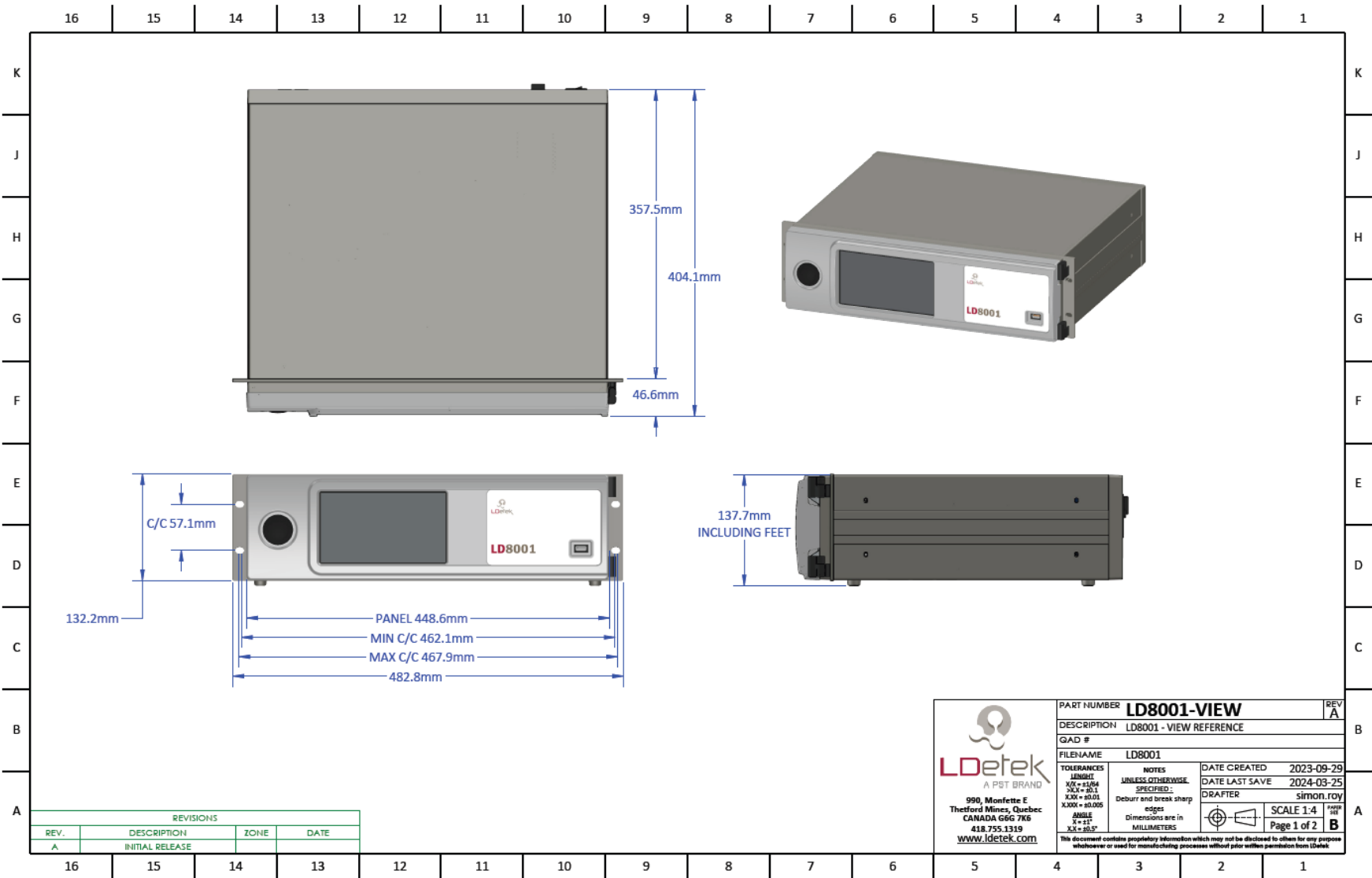

### 8.7. Back Facia Panel

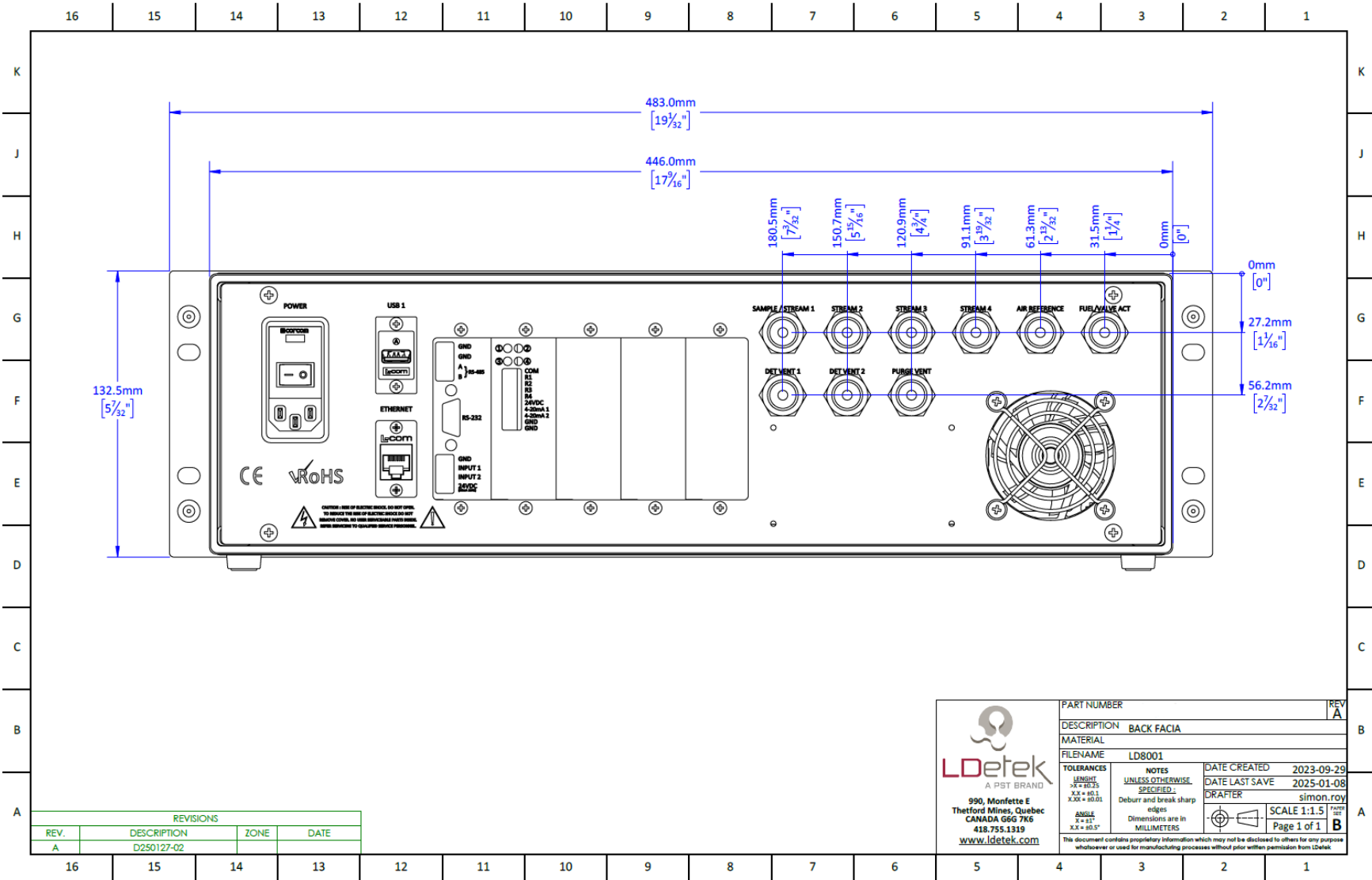

REVISIONS			
REV.	DESCRIPTION	ZONE	DATE
A	D250127-02		

<p>990, Monfette E Thetford Mines, Quebec CANADA G5G 7K6 418.755.1319 www.ldetek.com</p>	PART NUMBER	REV
	DESCRIPTION	BACK FACIA
	MATERIAL	
	FILENAME	LD8001
TOLERANCES	NOTES	DATE CREATED
LENGTH XX + 0.25 XX + 0.1 XXX + 0.01	UNLESS OTHERWISE SPECIFIED: Deburr and break sharp edges Dimensions are in MILLIMETERS	2023-09-29
ANGLE		DATE LAST SAVE
3 ± 15° X ± 15°		2025-01-08
		DRAFTER
		simon.royt
		SCALE 1:1.5
		Page 1 of 1
This document contains proprietary information which may not be disclosed to others for any purpose whatsoever or used for manufacturing processes without prior written permission from LDetek		

## 9. Maintenance and troubleshooting

Feel free to contact LDefetek at [support@ldetek.com](mailto:support@ldetek.com). if you want the maintenance schedule specific to your analyzer.

### 9.1. Spare part list

The below table shows consumables and capital spare parts that can be required in a LD8001. Consumables are parts that will deteriorate over time and must be replaced periodically.

Capital parts on the other end are parts that are known to have a long life and/or a small chance of failure. However, failure would cause a shutdown of the equipment because it would take some time to get a replacement part.

Part #	Description	Type	Replacement frequency
LDT-H2O-50	Moisture trap 50cc	Consumable	1 years
HCD-LD8001	Replacement HCD for LD8001 for sample He	Consumable	3-5 years
FanK-LD8001	Replacement fan	Consumable	3-5 years
Zero-gas-purifier-LD8001	Replacement purifier for zero gas free model	Consumable	3-5 years
Compact-LDP1000	Replacement purifier	Consumable	3-5 years
FK-LD8001	Fuse kit for LD8001	Capital part	N/A
PED-LD8001	Replacement PED for LD8001	Capital part	N/A
LCD-LD8001	TFT LCD display for FL8001	Capital part	N/A
Master-PCB-V1-LD8001	Master board for LD8001	Capital part	N/A
Bus-PCB-V1-LD8001	Bus board for LD8001	Capital part	N/A
PED-PCB-V1-LD8001	PED board for LD8001	Capital part	N/A
Flow-PCB-V1-LD8001	Flow board for LD8001	Capital part	N/A
Oven-PCB-V1-LD8001	Oven board for LD8001	Capital part	N/A
Multi-PCB-V1-LD8001	Multi board for LD8001	Capital part	N/A
Power-PCB-V1-LD8001	Power board for LD8001	Capital part	N/A

### 9.2. Tools

Some tools are required when doing a start-up, maintenance or troubleshooting on the LD8001. The below table shows the list of tools that can become handy. These tools are

separated into two categories – general and repair.

Tools in the category general are useful to do common tasks like start-ups, shut offs or maintenance. For advanced users that intend to do repair tasks, tools in the category repair will be useful. Please note that to attend repairs, tools from the category general are required.

Part #	Description	Category
ScrewdriverPH2	Philips screwdriver #2	General
Wrench1/4	Wrench ¼"	General
Wrench3/8	Wrench 3/8"	General
Wrench7/16	Wrench 7/16"	General
Flowmeter500ml	Flow meter 0-500ml/min	General
1/16TubeCuttingTool	1/16" Tube Cutting tool. Used to cut 1/16" tubing inside the analyzer.	Repair
FittingPliers	C-vice grip (4LW) 1/16 fittings pliers.	Repair
RestrictorPliers	Channellock909 reworked for orifices adjustment.	Repair
5/64" Hex Allen Key	5/64" Hex Allen Key for LDepe adjustment.	Repair

### 9.3. Maintenance procedures

This section will try to show maintenance procedures. Feel free to contact LDetek at [support@ldetek.com](mailto:support@ldetek.com). if you need clarifications.

#### 9.3.1. How to replace the HCDs in a LD8001

1. Turn off the LD8001 by putting the power switch off.
2. With a Philip screwdriver, unscrew the 4 screws that are holding the top cover There are 2 screws on each side of the analyzer.
3. Remove the 2 screws on each side of the HCD box.
4. Carefully remove the HCDs from the box. The heater should be screwed on the HCD, and the temperature sensor will be mounted inside.
5. Remove the heater by unscrewing it from the stainless block and pull out the temperature sensor.
6. Remove the inlet and outlet of the HCD module using a wrench 7/16". The face seal gasket should fall out and you can discard it.
7. Place new gaskets on the new HCD and connect the inlet/outlet.
8. Re-install the temperature sensor and the heater on the new HCD.
9. Reinstall the HCD in its box and put back the 2 screws.
10. Power on the LD8001 and wait 24 hours and before doing a calibration check.

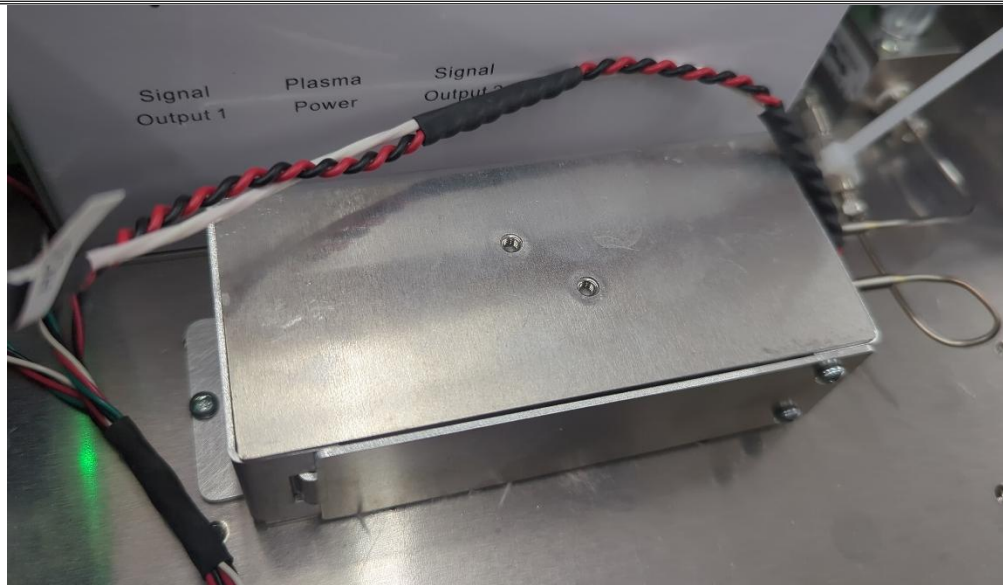

Figure 12: HCD box

### 9.3.2. How to replace the fan in a LD8001

1. Turn off the LD8001 by putting the power switch off.
2. With a Philip screwdriver, unscrew the 4 screws that are holding the top cover. There are 2 screws on each side of the analyzer.
3. You will then have access to the fan located on the back. Disconnect the white connector on the bus board to remove the power from the fan.
4. Remove the fixing screws and replace the fan with a new one.
5. Reconnect the white connector and close the top cover.

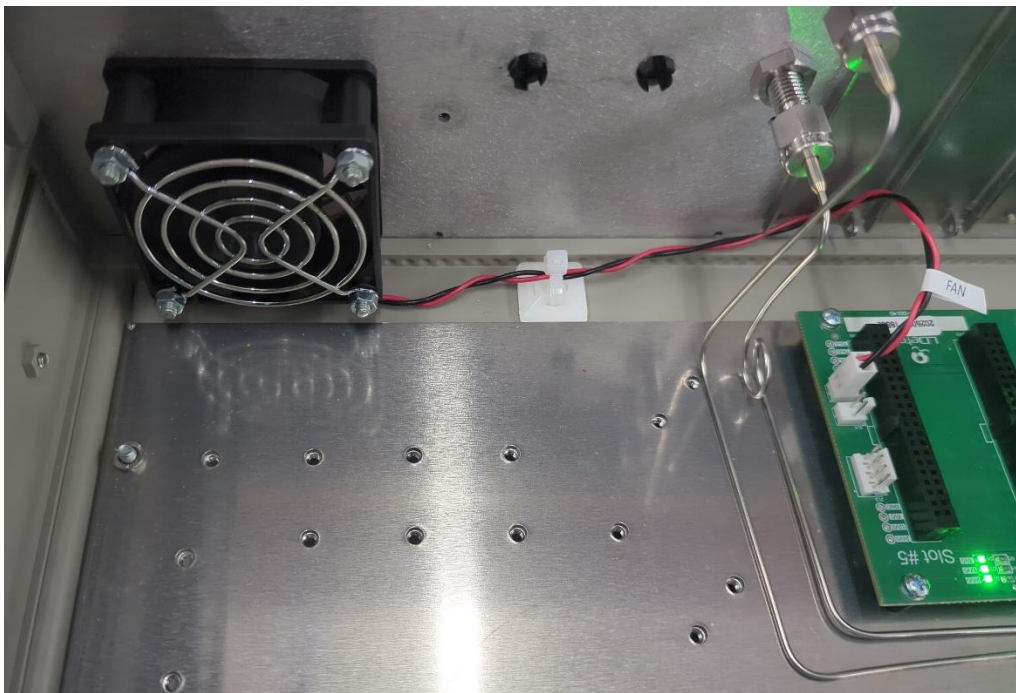

Figure 13: LD8001 fan

### 9.3.3. How to calibrate the 4-20mA module

The Analog Output has already been calibrated by LDetek before and shouldn't be recalibrated under normal circumstances. In the eventuality that the Analog Output must be recalibrated, the procedure below explains how to proceed with the 4-20mA calibration.

1. Go to Home > Settings and click on 4-20mA1.



2. Click on "Calib 4mA and measure the current on the LD8001 back panel. If needed, refer to the drawing on section 8.3.



3. Enter the value you measured and click on "Apply".

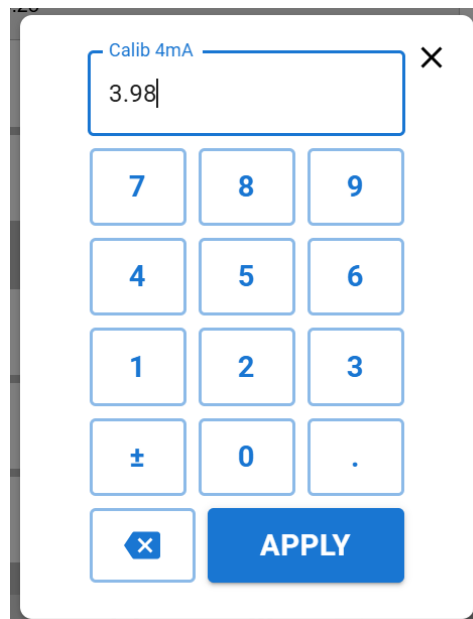

4. Repeat step 2 and 3 for 20mA.

5. Once done, you can test the calibration by clicking on “Force Value”. Note that you must click on “Reset Force” when done.

## 9.4. Troubleshooting

### 9.4.1. Alarm list

Alarm name	Description
Flow deviation on "FlowID"	This alarm shows that the flow of a specific module deviates from the setpoint.
Temperature deviation on "OvenID"	This alarm shows that the temperature of a specific oven deviates from the setpoint.
Detector off on "DetectorID"	This alarm indicate that the detector is not powered ON.
Temperature out of bound	This alarm indicate that the temperature measurement is outside of the sensor's limits. This generally happen if the sensor is disconnected or malfunctioning.
Flow out of bound	This alarm indicate that the flow measurement is outside of the sensor's limits. This generally happen if the sensor is disconnected or malfunctioning.

### 9.4.2. Low flow/flow deviation on sample

1. Check if the sample flow setpoint matches the value in the document operating parameters. The flow setpoint can be found in the menu Settings>>Settings>>Flow>>Sample.
2. Check if the sample pressure matches the value in the document operating parameters. It should be 3-30 psig for most systems.
3. Measure the flow with a flow meter connected to the sample vent of the LD8001.
4. Contact LDefek support ([support@ldetek.com](mailto:support@ldetek.com)) with the results obtained in the previous steps.

### 9.4.3. Detector off

1. Make sure that there is no active alarm. If there are alarms, they must be resolved.
2. Check if the raw signals for the sensors match the values shown in the document "Operating Parameters".
3. Open the top cover and check if the connectors on the detectors are well connected.

- 
4. Contact LDefek support ([support@ldetek.com](mailto:support@ldetek.com)) with the results obtained in the previous steps.

#### **9.4.4. Defective 4-20mA module**

1. Recalibrate the defective module as per section 9.3.3.
2. Contact LDefek support ([support@ldetek.com](mailto:support@ldetek.com)) with the results obtained in the previous steps.

#### **9.4.5. Unstable measurements**

1. Make sure that there is no active alarm. If there are alarms, they must be resolved.
2. Make sure that the calibration has been done properly.
3. Contact LDefek support ([support@ldetek.com](mailto:support@ldetek.com)) with the results obtained in the previous steps.

#### **9.4.6. Leak finding procedure**

Bad readings often come from Air contamination caused by a leak. These leaks can be in the analyzer or before. A leak before the analyzer can be anywhere from the sampling point until the internal sample proportional valve. This includes cylinders, tanks, trucks, regulator, tubing, fittings, etc. The following steps will help you understand from where the leak is coming from.

1. Set the sample flow to 100ml/min This can be done by double-clicking on the sample flow from the main menu.
2. Set the sample pressure to 10 psig and let the analyzer stabilize for 30 minutes.
3. Note the final concentration.
4. Decrease the sample pressure to 3 psig.
5. Make sure that the sample flow is still at the setpoint.
  - a. If there are no leaks, there won't see any noticeable changes in the concentration (<0.5ppm).
  - b. If there is a dead volume, the concentration will go up and start to decrease until it goes back to the original value.
  - c. If the ppm reading go up and stays high, it means that there is a leak between the regulator and the proportional valve.

Before trying to fix this leak, the same test should be done using another gas source (e.g. zero gas, span gas, etc.). If the same leak is observed, it means that the leak is in a flow path common to all of the sample source.

If there aren't any leaks before the proportional valve, the following tests can help determine if there is a leak after.

- 
1. Set the sample flow to 100ml/min This can be done by double-clicking on the sample flow from the main menu.
  2. Set the sample pressure to 10 psig and let the analyzer stabilize for 30 minutes.
  3. Note the final concentration.
  4. Set the sample flow to 200ml/min.
    - a. If there are no leaks, there won't see any noticeable changes in the concentration (<0.5ppm).
    - b. If there is a leak, the concentration will go down.

If a leak is detected, you can try to retighten the fittings one by one. It is recommended to wait 10 sec before each try to see whether there are changes in the reading.











**LD**etek

Where **innovation** leads to **success**